

TESTATA PANDA 215/515 C/PIASTRINA			REF. 3780 P
POS	REF.	DESCRIZIONE	N°
1	117	CAVO ELETTRICO 2X1	1
2	138	PASSACAPO	1
3	139	BLOCCACAPO	1
4	1006	VITE PFU TMT PHL 5X20 ZN.NERA P/R	2
5	3464	MORSETT. 300/500 EU/NEVRAD	1
6	3733	MANIGLIA PANDA	1
7	2627	VITE PAT TMT PHL 5X40 ZN.NERA	4
8	1006	VITE PFU TMT PHL 5X20 ZN.NERA P/R	2
9	1026	VITE PAT TMT PHL 5X30 ZN.NERA	2
10	1026	VITE PAT TMT PHL 5X30 ZN.NERA	2
11	3734	COPERCHIO PANDA	1
12	326	INTERUTTORE	1
13	3937	FILTRO MTP/65 Ø 95	1
14	1050	VITE PAT TMT PHL 5X35 ZN.NERA	6
15	2738-1	COPERTURA99 S/FORI	1
16	3969	RONDELLAH=8 Ø 85 X65	1
17	310	ANELLO MOTORE PLAST.H=15	1
18	3900	FILTRO MTP/65 Ø 160-120 H=88	1
19	2627	VITE PAT TMT PHL 5X40 ZINC.	6
20	1006	VITE PFU TMT PHL 5X20 ZN.NERA P/R	4
21	2591-1	FERMAMOTORE 99	1
22	3901	GUARNIZIONE A L S/F H=5,5	1
23	3891/E	MOT. BD302 1000W 220-240V-50/60	1
24	3901	GUARNIZIONE A L S/F H=5,5	1
25	3866	RONDELLAMTP/65 MM.18 Ø 230X145	1
26	1189 GP	BASAMENTO 500 C/GUARN.E PIASTRINA	1
27	3189	VITE TC CROCE M5X30 UNI 7989	1
*	1107	CAVETTO C/RESISTENZE	1
*	7632/PI TP	KIT ELE TTR. 40 CM MOTORE POKE-IN-TP	1
*	1106	FASCETTA	1

KIT FILTRANTE 500 CONICO SAN.COMPL.			REF. 3247 SAN
POS	REF.	DESCRIZIONE	N°
1	3706	BUSSOLA D.8 PLAST.	4
2	3724	VITE PAT TMT PHL 5X25 IN OX	4
3	2823-1	CORPO ANTISCHIUMA 99 ALTO	1
4	3138	FILTRO RETE 0.3 D.90 H=45	1
5	2676	GALLEGGIANTE 99 ALTO	1
6	507	ANELLO PORTAFILTRO SERIE 500	1
7	2860 SAN	FILTRO POLYESTERE 300 CONICO SAN.	1
8	2859	CESTELLO 300 CONICO	1

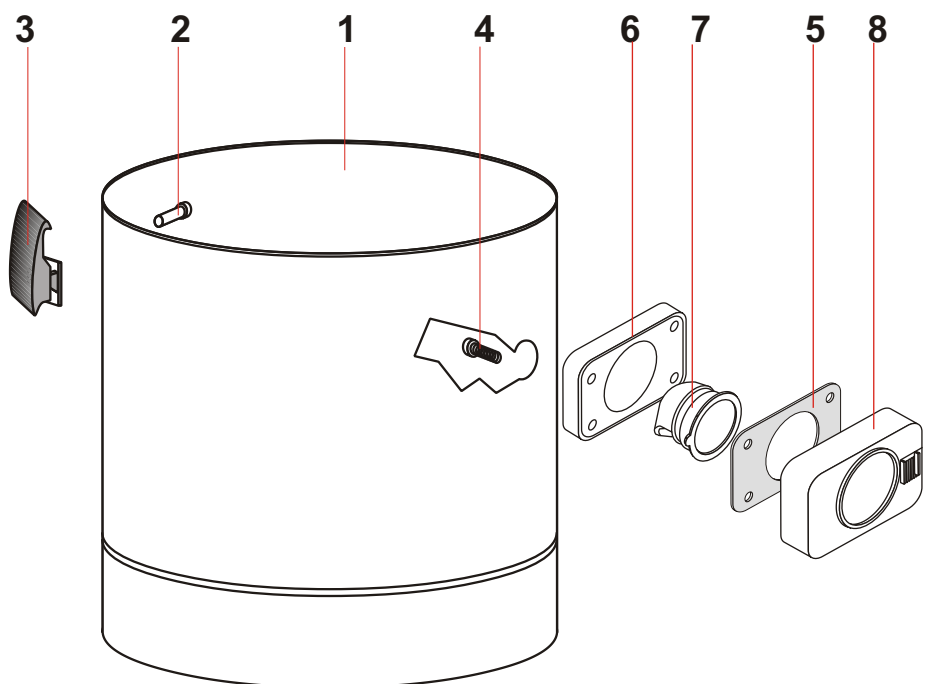
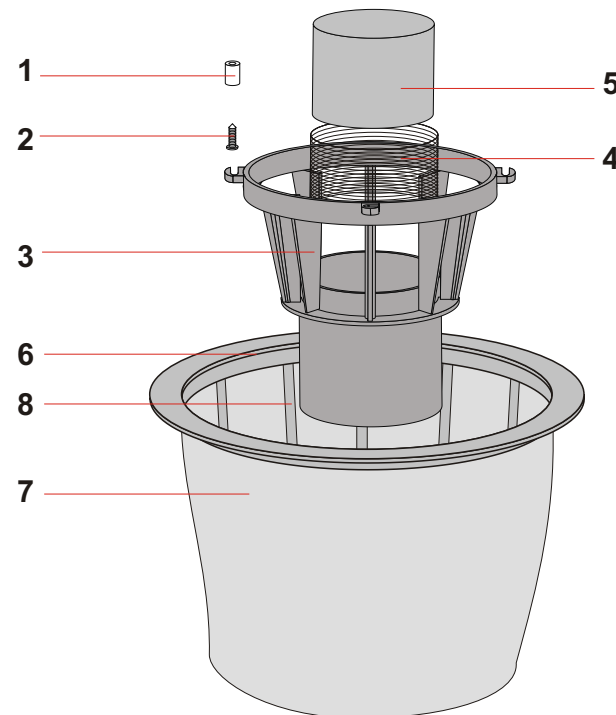

CARRELLO 202 QUADRO			REF. 1219
POS	REF.	DESCRIZIONE	N°
1	1218	CORPO CARRELLO QUADRO	1
2	558	RUOTA CARRELLO BOX	4

FUSTO 215 AISI 430 COMPLETO			REF. 2950 PANDA
POS	REF.	DESCRIZIONE	N°
1	2949	FUSTO 215 AISI 430	1
2	1301	RIVETTO 5X11	4
3	1847/S	GANCIO PLASTICA COMPLETO	2
4	1026	VITE TRUCC.T 1/2 TONDA CROCE 5X30	4
5	2846	GUARNIZIONE Ø 38	1
6	2586	GUARNIZIONE R 205	1
7	2593	DEFLETTORE 99	1
8	2652 A	BOCCHETTONE R155	1

