



INTERPUMP GROUP



M SERIES



I	ISTRUZIONI D'USO
GB	INSTRUCTIONS FOR USE
F	MODE D'EMPLOI
D	BEDIENUNGSANLEITUNG
E	INSTRUCCIONES DE USO
P	INSTRUÇÕES DE USO

Questo manuale deve essere letto e compreso in accordo al libretto generico "Istruzioni d'uso e manutenzione".
 This manual must be read and followed in accordance with the generic "Instructions for Use and Maintenance" booklet.
 Ce manuel doit être lu et compris en accord avec la notice générale " Mode d'emploi et d'entretien ".
 Dieses Handbuch ist in Verbindung mit dem allgemeinen Handbuch " Gebrauchs- und Wartungsanleitung " zu lesen und zu verstehen.
 Este manual debe leerse y comprenderse de acuerdo con el manual general "Instrucciones de uso y mantenimiento"
 Este manual deve ser lido e interpretado de acordo com o livro genérico "Instruções de uso e manutenção"

Monofase – Singlephasé – Monophase – Wechselstrom – Monofásica – Monofásico : 1 ~ 50 Hz

Protezione motore – Motor protection – Degré d'étanchéité – Schutz gruppe – Protector motor – Protecção do motor : IPX5

Classe isolamento – Insulation class – Classe d'isolation – Isolationsklasse – Clase aislamiento – Classe isolamento : F

Rumorosità – Noise level – Niveau sonore – Schallpegel – Nivel acustico – Nivel acustico : Lw dB(A) 94

Type Type Tipo Tipo	Flow rate Débit Förderstrom Caudal Portata		Pressure Pressione Druck Presion Pressione			rpm t/m upm r/m g/m	Power Puissance Leistung Potencia Potenza	V / A		Weight Poids Gewicht Peso Massa		
	L/min	gpm	bar	MPa	psi					kW	Kg	Ibs
12/100	12	3.17	100	10	1450	1400	3.20	230	14.7	32.5	71.6	0.4
10/130	10	2.64	130	13	1885	1400		240	13.6	32.5	71.6	0.4
Monofase – Singlephasé – Monophase – Wechselstrom – Monofásica – Monofásico : 1 ~ 60 Hz												
957	15.9	4.20	75	7.5	1100	1700	3.20	220	15.5	32.5	71.6	0.4
954	13.6	3.60	90	9	1300	1700				32.5	71.6	0.4
951	11.5	3.04	105	10.5	1525	1700				32.5	71.6	0.4
Trifase – Threephasé – Triphase – Drehstrom – Trifásica – Trifásico : 3 ~ 50 Hz												
14/120	14	3.69	120	12	1740	1400	3.80	230	12.5	28.7	63.3	0.4
12/140	12	3.17	140	14	2030	1400		400	7.2	28.7	63.3	0.4
17/130	17	4.50	130	13	1885	2800	5.00	230	15.8	32.0	70.5	0.4
15/150	15	3.96	150	15	2175	2800		240	14.5	32.0	70.5	0.4
13/180	13	3.43	180	18	2610	2800		400	9.2	32.0	70.5	0.4
								415	8.5	32.0	70.5	0.4
Trifase – Threephasé – Triphase – Drehstrom – Trifásica – Trifásico : 3 ~ 60 Hz												
960	13.6	3.60	140	14	2030	1700	4.60	440	7.2	28.7	63.3	0.4
961	15	3.96	150	15	2175	3400	5.00	220	15.8	32.5	71.6	0.4
								380	9.2			

** Fissare con Loctite 542 col. ROSSO
 ** Affix with Loctite 542 col. RED
 ** Fixer avec de la Loctite 542 couleur ROUGE
 ** Mit Loctite 542 ROT befestigen
 ** Fijar con Loctite 542 col. ROJO
 ** Fixar com Loctite 542 cor. VERMELHA

* Fissare con Loctite 270 col. VERDE
 * Affix with Loctite 270 col. GREEN
 * Fixer avec de la Loctite 270 couleur VERT
 * Mit Loctite 270 GRÜN befestigen
 * Fijar con Loctite 270 col. VERDE
 * Fixar com Loctite 270 cor. VERDE

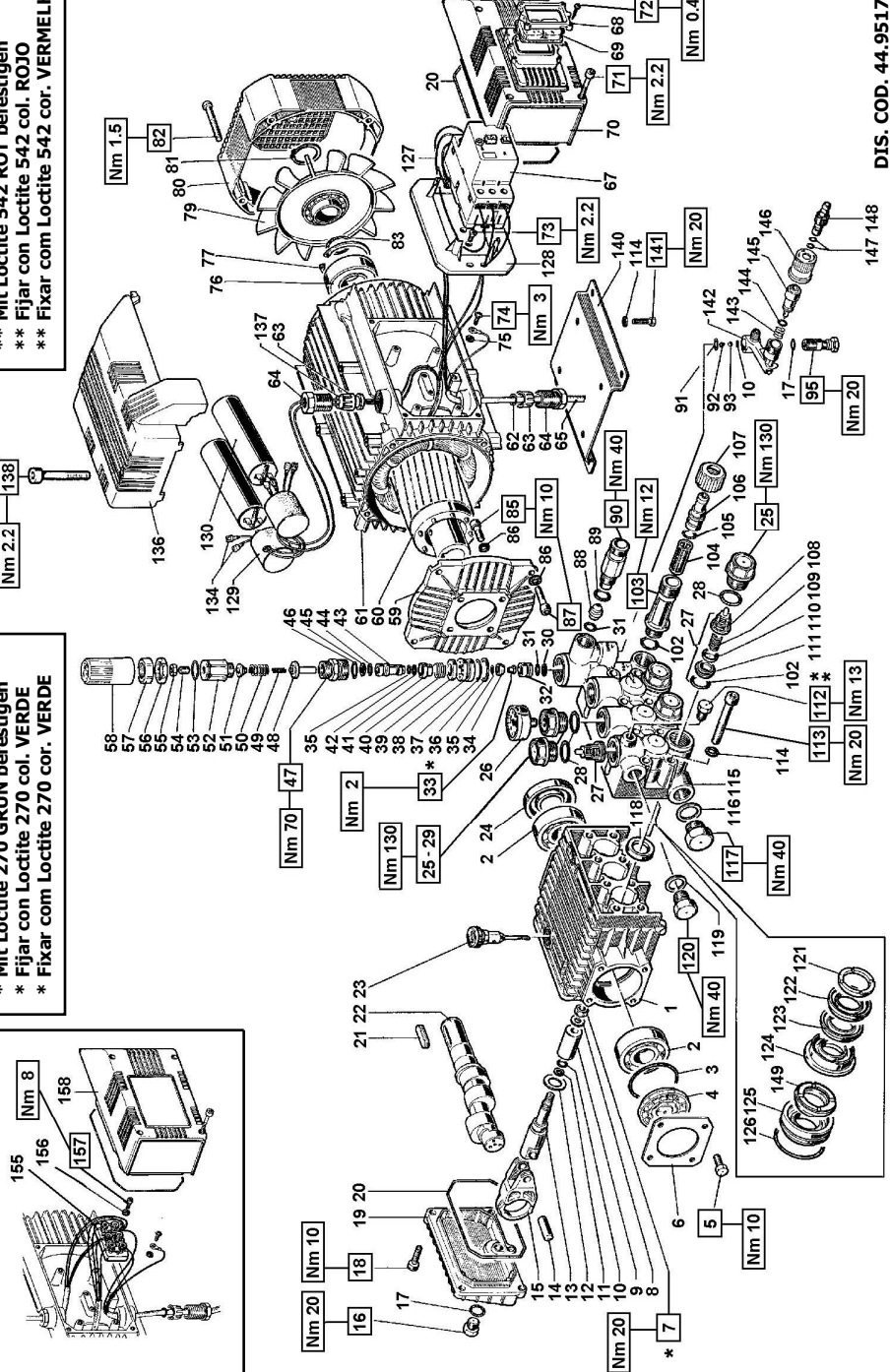

DIS. COD. 44.9517.00

KIT RICAMBI – SPARE KITS

KIT Nr.	KIT 23	KIT 94	KIT 123	KIT 124	KIT 137	PISTONE – PISTON Ø 15						PISTONE – PISTON Ø 18					
						KIT 88	KIT 89	KIT 90	KIT 125	KIT 130	KIT 126	KIT 127	KIT 128	KIT 129	KIT 131		
Posizioni Incluse Positions Included	118	10-17-31 89-91-92 93-143-144 147	102-108 109-110 111 (27)	25-28	30-31-32-33 34-35-36-37 38-39-40-41 42-43-44-45	122-123 149	124	121	125-126 149	121-122 123-124 125-126 149	125-126 149	123-122 149	124	121	121-122 123-124 125-126 149		
Nr. Pcs.	3	1	6	6	1	3	3	6	3	1	3	3	3	6	1		



PISTONE – PISTON Ø15	
M10-130	M951
PISTONE – PISTON Ø18	
M12-100	M957

**M10-130 M12-100
M951 M954 M957**

POS	COD.	DESCRIZIONE – DESCRIPTION - KIT	NR
1	44.0100.22	Carter pompa	1
2	91.8328.00	Cuscinetto a sfera 6305	2
3	90.4097.00	OR 6 55.56x3.53 (159)	1
4	44.2118.01	Distanziale con indicatore	1
5	99.1807.00	Vite M6x10 UNI 5739	4
6	50.1500.74	Coperchio laterale carter	1
7	92.2216.00	Dado M8x13x5 - inox	3
8	44.2115.70	Rosetta Ø 8 con collare	3
9	52.0400.09 44.0401.09	Pistone Ø 15x37,5 Pistone Ø 18x37,5	3
10	90.3572.00	OR Ø 5.28x1.78 (2021)	94
11	90.5022.00	Anello antiest. Ø 6.2x9x1.5	3
12	96.7350.66	Rosetta Ø 16x28x1	3
13	44.0500.66	Guida pistone	3
14	97.7340.00	Spinotto Ø 10x29.5	3
15	44.0300.22	Biella	3
16	98.2042.50	Tappo G 1/4"x9 TE17 – zinc.	1
17	90.3585.00	OR Ø 10.82x1.78 (2043)	94

POS	COD.	DESCRIZIONE – DESCRIPTION - KIT	NR
18	99.1837.00	Vite M6x14 UNI 5931	5
19	44.1600.22	Coperchio posteriore carter	1
20	90.3920.00	OR Ø 101.27x2.62 (3400)	2
21	91.4892.00	Linguetta 8x7x35 UNI 6604	1
22	44.0206.35 44.0203.35	Albero C.13 – M10-130 M951 M957 Albero C.11 – M12-100 M954	1
23	98.2103.00	Tappo carico olio G 3/8"	1
24	90.1641.00	Anello rad. Ø 25x62x10	1
25	98.2226.00	Tappo M24x1.5x17	124
26	94.5824.00	Manometro	1
27	36.7115.01	Gruppo valvola aspiraz./mandata 123	6
28	90.3847.00	OR Ø 20.24x2.62 (3081)	124
29	98.2227.00	Tappo M24x1.5 per manometro	1
30	90.5065.00	Anello antiest. Ø 10.6x15x2	137
31	90.3822.00	OR Ø 9.92x2.62 (112)	94-137
32	36.3164.66	Sede valvola	137
33	99.1509.00	Vite M5x7.5 – INOX	137
34	36.3190.66	Valvola sferica	137
35	90.3575.00	OR Ø 6.72x1.78 (106)	137
36	90.5144.00	Anello antiest. Ø 22x25x1.5	137
37	90.3600.00	OR Ø 21.92x1.78 (2087)	137
38	36.3229.70	Guida valvola	137
39	36.3231.51	Valvola	137
40	94.7485.00	Molla Ø 18.5x11.5	137
41	36.3230.70	Distanziale	137

POS	COD.	DESCRIZIONE – DESCRIPTION - KIT	NR
42	90.5025.00	Anello antiest. Ø 7x10x1.5	137
43	36.3234.70	Pistoncino di comando	137
44	90.3820.00	OR Ø 9.13x2.62 (109)	137
45	90.5052.00	Anello antiest. Ø 9.6x14x1.5	137
46	90.3857.00	OR Ø 23.81x2.62 (132)	1
47	36.3228.70	Boccola di guida	1
48	36.3233.70	Piattello inferiore molla	1
49	94.7345.00	Molla Ø 7.6x29	1
50	94.7436.00	Molla Ø 15x35	1
51	36.3169.70	Piattello molla	1
52	36.3185.70	Registro pressione	1
53	90.3598.00	OR Ø 20.35x1.78 (2081)	1
54	99.3054.00	Vite M8x20 UNI 5923	1
55	92.2218.00	Dado M8x5x13 UNI 5589	1
56	92.2935.00	Dado M28x1.5	1
57	36.3186.70	Ghiera per registro pressione	1
58	36.3187.51	Pomolo regolazione valvola	1
59	10.0501.22	Flangia	1
60	43.3401.02	Rotore comp. 3 CV – Mon.	1
61	43.3201.02 43.3203.02 43.3208.02	Statore comp. 3 CV – Mon. – 220 V Statore comp. 3 CV – Mon. – 230V 60 Hz Statore comp. 3 CV – Mon. – 240 V	1
62	90.4028.00	OR Ø 9.12x3.53 (4036)	1
63	43.2128.51	Pinza pressa cavo	2
64	43.2127.51	Pressa cavo	2
65	10.7269.01	Cavo 5.8 m.	1

POS	COD.	DESCRIZIONE - DESCRIPTION - KIT	NR
137	43.2129.47	Tenuta cavetti	1
138	99.1705.00	Vite M5x65 UNI 5931	1
140	42.2000.74	Piedino motore - OPTIONAL	1
141	99.3067.00	Vite M8x25 UNI 5739 - OPTIONAL	4
142	36.3181.51	Corpo dosatore	1
143	94.7383.00	Molla Ø 9,75x10	94
144	90.3580.00	OR Ø 8,73x1,78 (108)	94
145	36.2564.70	Otturatore per dosatore	1
146	36.2565.51	Pomolo regolazione detersivo	2
147	90.3570.00	OR Ø 4,48x1,78 (2018)	94
148	36.2566.70	Innesto porta gomma	3
	90.2617.00	Anello ten. alt. Ø 15x25x5,8 LP	
149	90.2684.00	Anello ten. alt. Ø 18x30x6,8 LP	3
		127-131	
155	93.5745.00	Basetta	1
156	96.6910.00	Rosetta Ø 5,3x9x0,6	2
157	99.1537.00	Vite M5x12 UNI 5931	2
158	43.2111.51	Copri basetta - vers. senza interrutt.	1

POS	COD.	DESCRIZIONE - DESCRIPTION - KIT	NR
107	92.9828.00	Ghiera G 3/4" - OPTIONAL	1
108	36.2025.51	Guida valvola	123
109	94.7376.00	Molla Ø 9,4x14,8	123
110	36.2001.76	Valvola	123
111	36.2003.66	Sede valvola	123
112	98.1966.00	Tappo G 1/8"x8	1
113	99.3175.00	Vite M8x60 UNI 5931	8
114	96.7014.00	Rosetta Ø 8,4x13x0,8	12
115	44.1201.41	Testata pompa - M10-130 M951	1
	44.1205.41	Testata pompa - M12-100 M954 M957	
116	96.7514.00	Rosetta Ø 21,5x27x1,5	1
117	98.2176.00	Tappo G 1/2"x10	1
118	90.1614.00	Anello rad. Ø 20x30x5	23
119	96.7380.00	Rosetta Ø 17,5x23x1,5	1
120	98.2100.00	Tappo G 3/8"x13	1
121	51.1000.51	Anello di testa Ø 15	90-130
	44.1001.51	Anello di testa Ø 18	129-131
122	90.2620.00	Anello ten. alt. Ø15x25x5/3,1 HP	88-130
	90.2682.00	Anello ten. alt. Ø 18x30x6/3,5 HP	127-131
123	90.2622.00	Anello RESTOP Ø 15x25x5/3,1	88-130
	90.2683.00	Anello RESTOP Ø 18x30x6/3,5	127-131
124	52.2166.70	Anello intermedio Ø 15	89-130
	44.2161.70	Anello intermedio Ø 18	128-131
125	44.0800.70	Anello di fondo Ø 15	125-130
	44.0801.70	Anello di fondo Ø 18	126-131
126	90.3612.00	OR Ø 31,47x1,78	125-126-130-131
127	42.2115.86	Cavo per interruttore	1
128	43.2118.51	Piastra di fissaggio	1
129	42.2121.51	Cappello per condensatore	2
130	93.5648.00	Condensatore 40 µF	2
134	10.7332.01	Cavo collegamento condensatore	2
136	42.2124.51	Protezione condensatori	1

POS	COD.	DESCRIZIONE - DESCRIPTION - KIT	NR
67	93.5182.00	Interruttore magnetotermico - 220-240 V	1
68	43.2120.51	Mascherina interruttore	1
69	43.2119.47	Membrana interruttore	1
70	43.2113.51	Copri basetta	1
71	99.1720.00	Vite M5x70 UNI 5931	4
72	99.0744.00	Vite Ø 3x16 autoflettante	4
73	99.1540.00	Vite M5x12 UNI 7688	2
74	99.1515.00	Vite M5x12 UNI 7687	1
75	96.6913.00	Rosetta Ø 5,3x9x0,6	1
76	91.8372.00	Cuscinetto a sfere 6206	1
77	90.0850.00	Anello seeger Ø 62 UNI 7437	1
79	42.0300.51	Ventola	1
80	43.04.0051	Copri ventola	1
81	90.0655.00	Anello seeger Ø 28 UNI 7435	1
82	99.1658.00	Vite M5x45 UNI 7687	4
83	90.3863.00	OR Ø 28,25x2,62 (3112)	1
85	99.1867.00	Vite M6x18 UNI 5931	4
86	96.6938.00	Rosetta Ø 6,4x10x0,7	8
87	99.1897.00	Vite M6x25 UNI 5931	4
88	10.0076.66	Ugello - Nozzle Ø 2,5 (1,2÷1,7 l/min.)	1
89	90.3832.00	OR Ø 13,95x2,62 (3056)	94
90	10.0078.70	Nipplo G 3/8" con Ø 3 - STANDARD	1
	10.0147.70	Nipplo M22x1,5 con Ø 3	
91	90.3582.00	OR Ø 9,25x1,78 (2037)	94
92	94.8217.00	Molla conica Ø 4,37x3x11	94
93	97.4782.00	Sfera Ø 7/32"	94
95	36.2563.70	Sede valvola	1
102	90.3841.00	OR Ø 17,13x2,62 (3068)	123
103	36.3182.51	Nipplo aspirazione G 3/4"	1
104	92.8925.00	Filtro 12x35	1
105	90.3828.00	OR Ø 12,37x2,62 (3050)	1
106	36.2569.51	Portagomma aspirazione - OPTIONAL	1

**VERSIONE CON TOTALSTOP – TOTALSTOP VERSION
VERSION AVEC LE TOTALSTOP – VERSION MIT TOTALSTOP
VERSIÓN CON EL TOTALSTOP – VERSÃO COM TOTALSTOP**

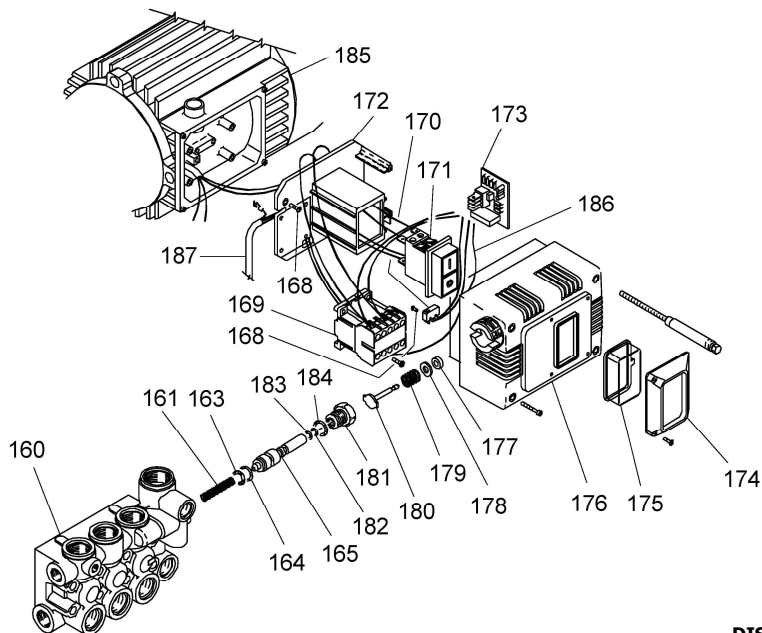

DIS. COD. 44.9527.00

POS	COD.	DESCRIZIONE – DESCRIPTION - KIT	NR
160	44.1210.41 44.1211.41	Testata pompa Ø 15 Testata pompa Ø 18	1
161	94.7341.00	Molla Ø 7.5x37.5	1
163	90.5052.00	Anello antiest. Ø 9.13x14x1.5	306 1
164	90.3819.00	OR Ø 9.13x2.62 (109)	306 1
165	10.0799.70	Pistoncino di comando	306 1
168	99.1450.00	Vite Ø 4.2x16 autofilettante	5
169	93.6342.00	Mini contattore 230V	1
170	10.7367.02	Cablaggio mini interruttore	1
171	93.5190.00	Interruttore termico bipolare 230V	1
172	43.2121.51	Piastra fissaggio interruttore	1
173	93.6430.00	Scheda termica temporizzata 230V	1
174	43.2123.51	Mascherina interruttore	1
175	43.2122.47	Membrana interruttore	1

POS	COD.	DESCRIZIONE – DESCRIPTION - KIT	NR
176	43.2114.51	Copri basetta	1
177	90.2532.00	Anello di tenuta Ø 6.32x12.7x3.96	1
178	96.7035.00	Rosetta Ø 8.4x17x1.6	1
179	94.7412.00	Molla Ø 13x30	1
180	43.2126.51	Pistoncino di comando	1
181	10.0800.70	Guida pistone Totalstop	306 1
182	90.5020.00	Anello antiest. Ø 5.2x8x1.5	306 1
183	90.3570.00	OR Ø 4.48x1.78 (2018)	306 1
184	90.3591.00	OR Ø 14x1.78 (2056)	306 1
185	43.3205.02 43.3206.02 43.3207.02	Statore comp. 3 CV – Mon. – 230V Statore comp. 3 CV – Mon. – 230V 60 HZ Statore comp. 3 CV – Mon. – 240V 60 HZ	1
186	10.7365.01	Cablaggio interruttore	1
187	10.7370.01	Cavo 5.8 m.	1

KIT Nr.	KIT 306
Posizioni include Positions included	163 – 164 – 165 181 – 182 – 183 - 184
Nr. Pcs.	1

** Fissare con Loctite 542 col. ROSSO
 ** Affix with Loctite 542 col. RED
 ** Fixer avec de la Loctite 542 couleur ROUGE
 ** Mit Loctite 542 ROT befestigen
 ** Fijar con Loctite 542 col. ROJO
 ** Fixar com Loctite 542 cor. VERMELHA

* Fissare con Loctite 270 col. VERDE
 * Affix with Loctite 270 col. GREEN
 * Fixer avec de la Loctite 270 couleur VERT
 * Mit Loctite 270 GRÜN befestigen
 * Fijar con Loctite 270 col. VERDE
 * Fixar com Loctite 270 cor. VERDE

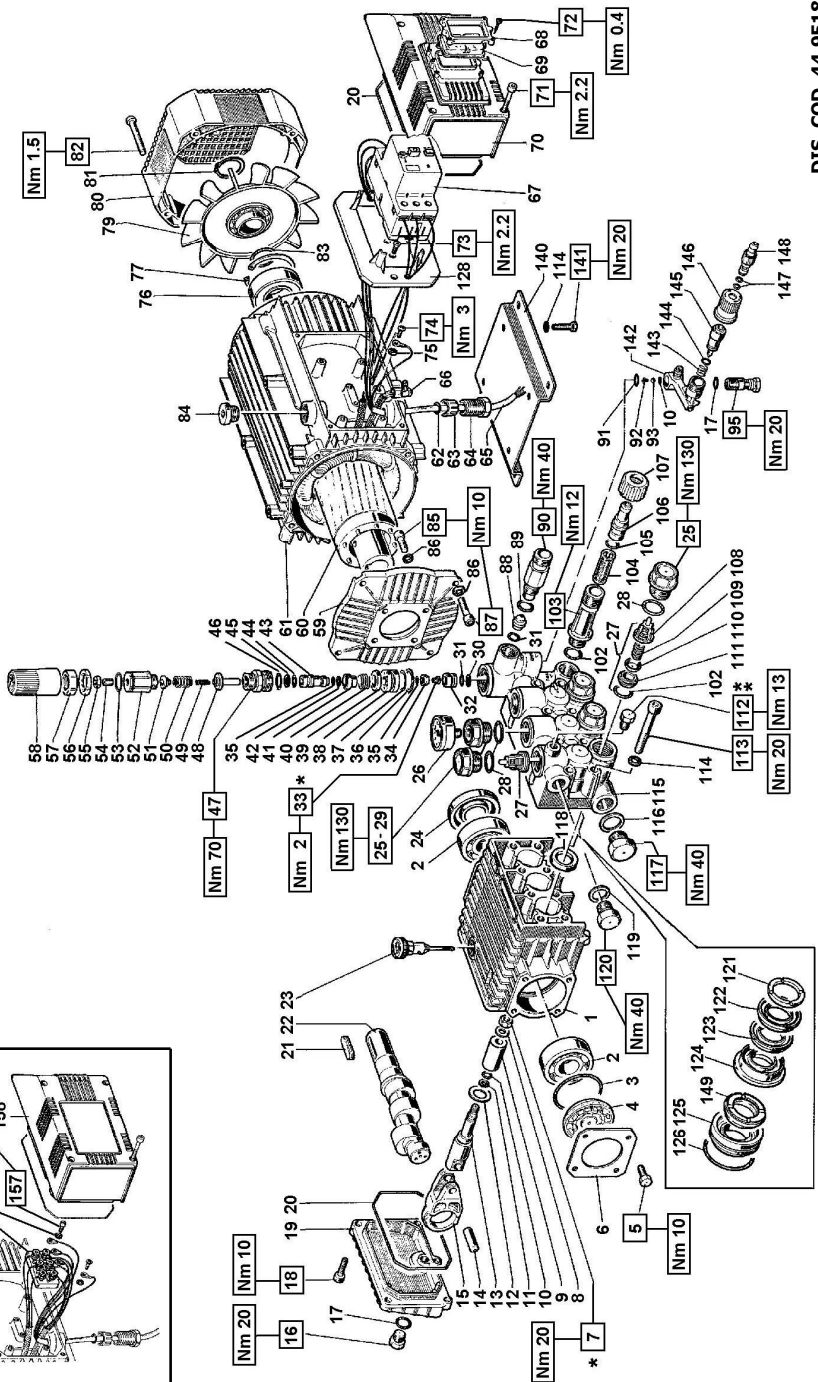
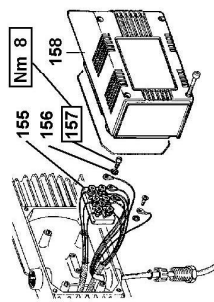

KIT RICAMBI – SPARE KITS

KIT Nr.	KIT 23	KIT 94	KIT 123	KIT 124	KIT 137	PISTONE – PISTON Ø 15						PISTONE – PISTON Ø 18					
						KIT 88	KIT 89	KIT 90	KIT 125	KIT 130	KIT 126	KIT 127	KIT 128	KIT 129	KIT 131		
Posizioni Incluse Positions Included	118	10-17-31 89-91-92 93-143-144 147	102-108 109-110 111 (27)	25-28	30-31-32-33 34-35-36-37 38-39-40-41 42-43-44-45	122-123 124 149	124	121	125-126 149	121-122 123-124 125-126 149	125-126 149	123-122 124 149	121-122 123-124 125-126 149				
Nr. Pcs.	3	1	6	6	1	3	3	6	3	1	3	3	6	1			



PISTONE – PISTON Ø15

M13-180 M15-150 M17-130 M961

PISTONE – PISTON Ø18

M12-140 M14-120 M960

POS	COD.	DESCRIZIONE – DESCRIPTION - KIT	NR
18	99.1837.00	Vite M6x14 UNI 5931	5
19	44.1600.22	Coperchio posteriore carter	1
20	90.3920.00	OR Ø 101.27x2.62 (3400)	2
21	91.4892.00	Linguetta 8x7x35 UNI 6604	1
22	44.0200.35	Albero C.8.5 - M13-180 M961	
	44.0203.35	Albero C.11 - M12-140 M15-150 M960	1
	44.0206.35	Albero C.13 - M14-120 M17-130	
23	98.2103.00	Tappo carico olio G 3/8"	1
24	90.1641.00	Anello rad. Ø 25x62x10	1
25	98.2226.00	Tappo M24x1.5x17	124
26	94.5824.00	Manometro	1
27	36.7115.01	Gruppo valvola aspiraz./mandata 123	6
28	90.3847.00	OR Ø 20.24x2.62 (3081)	124
29	98.2227.00	Tappo M24x1.5 per manometro	1
30	90.5065.00	Anello antiest. Ø 10,6x15x2	137
31	90.3822.00	OR Ø 9,92x2,62 (112)	94-137
32	36.3164.66	Sede valvola	137
33	99.1509.00	Vite M5x7,5 – INOX	137
34	36.3190.66	Valvola sferica	137
35	90.3575.00	OR Ø 6,72x1,78 (106)	137
36	90.5144.00	Anello antiest. Ø 22x25x1,5	137
37	90.3600.00	OR Ø 21.92x1,78 (2087)	137
38	36.3229.70	Guida valvola	137
39	36.3231.51	Valvola	137
40	94.7485.00	Molla Ø 18,5x11,5	137
41	36.3230.70	Distanziale	137

POS	COD.	DESCRIZIONE – DESCRIPTION - KIT	NR
1	44.0100.22	Carter pompa	1
2	91.8328.00	Cuscinetto a sfere 6305	2
3	90.4097.00	OR 6 55,56x3,53 (159)	1
4	44.2118.01	Distanziale con indicatore	1
5	99.1807.00	Vite M6x10 UNI 5739	4
6	50.1500.74	Coperchio laterale carter	1
7	92.2216.00	Dado M8x13x5 - inox	3
8	44.2115.70	Rosetta Ø 8 con collare	3
9	52.0400.09	Pistone Ø 15x37,5	
	44.0401.09	Pistone Ø 18x37,5	3
10	90.3572.00	OR Ø 5,28x1,78 (2021)	94
11	90.5022.00	Anello antiest. Ø 6,2x9x1,5	3
12	96.7350.66	Rosetta Ø 16x28x1	3
13	44.0500.66	Guida pistone	3
14	97.7340.00	Spinotto Ø 10x29,5	3
15	44.0300.22	Biella	3
16	98.2042.50	Tappo G 1/4"x9 TE17 – zinc.	1
17	90.3585.00	OR Ø 10,82x1,78 (2043)	94

POS	COD.	DESCRIZIONE – DESCRIPTION - KIT	NR
42	90.5025.00	Anello antiest. Ø 7x10x1,5	137
43	36.3234.70	Pistoncino di comando	137
44	90.3820.00	OR Ø 9,13x2,62 (109)	137
45	90.5052.00	Anello antiest. Ø 9,6x14x1,5	137
46	90.3857.00	OR Ø 23,81x2,62 (132)	1
47	36.3228.70	Boccola di guida	1
48	36.3233.70	Piattello inferiore molla	1
49	94.7345.00	Molla Ø 7,6x29	1
50	94.7436.00	Molla Ø 15x35	1
51	36.3169.70	Piattello molla	1
52	36.3185.70	Registro pressione	1
53	90.3598.00	OR Ø 20,35x1,78 (2081)	1
54	99.3054.00	Vite M8x20 UNI 5923	1
55	92.2218.00	Dado M8x5x13 UNI 5589	1
56	92.2935.00	Dado M28x1,5	1
57	36.3186.70	Ghiera per registro pressione	1
58	36.3187.51	Pomolo regolazione valvola	1
59	10.0501.22	Flangia	1
60	43.3430.02	Rotore comp. 4 CV – Trif. – 220-380 V	1
	43.3460.02	Rotore comp. 5,5 CV – Trif. – 220-415 V	
61	43.3231.02	Statore comp. 4 CV – Trif. – 220-380 V	
	43.3261.02	Statore comp. 5,5 CV – Trif. – 230-380 V	
	43.3265.02	Statore comp. 5,5 CV – Trif. – 240-415 V	
	43.3268.02	Statore comp. 5,5 CV – Trif. – 220-380 V	
62	90.4028.00	OR Ø 9,12x3,53 (4036)	1
63	43.2128.51	Pirza pressa cavo	2

POS	COD.	DESCRIZIONE - DESCRIPTION - KIT	NR
128	43.2118.51	Piastra di fissaggio	1
140	42.2000.74	Piedino motore - OPTIONAL	1
141	99.3067.00	Vite M8x25 UNI 5739 - OPTIONAL	4
142	36.3181.51	Corpo dosatore	1
143	94.7383.00	Molla Ø 9,75x10	94
144	90.3580.00	OR Ø 8,73x1,78 (108)	94
145	36.2564.70	Otturatore per dosatore	1
146	36.2565.51	Pomolo regolazione detersivo	2
147	90.3570.00	OR Ø 4,48x1,78 (2018)	94
148	36.2566.70	Innesto porta gomma	3
149	90.2617.00	Anello ten. alt. Ø 15x25x5,8 LP	88-130
	90.2684.00	Anello ten. alt. Ø 18x30x6,8 LP	127-131
155	93.5745.00	Basetta	1
156	96.6910.00	Rosetta Ø 5,3x9x0,6	2
157	99.1537.00	Vite M5x12 UNI 5931	2
158	43.2111.51	Copri basetta - vers. senza interrutt.	1

POS	COD.	DESCRIZIONE - DESCRIPTION - KIT	NR
102	90.3841.00	OR Ø 17,13x2,62 (3066)	123
103	36.3182.51	Nipplo aspirazione G 3/4"	1
104	92.8925.00	Filtro 12x35	1
105	90.3828.00	OR Ø 12,37x2,62 (3050)	1
106	36.2569.51	Porta gomma aspirazione - OPTIONAL	1
107	92.9828.00	Ghiera G 3/4" - OPTIONAL	1
108	36.2025.51	Guida valvola	123
109	94.7376.00	Molla Ø 9,4x14,8	123
110	36.2001.76	Valvola	123
111	36.2003.66	Sede valvola	123
112	98.1966.00	Tappo G 1/8"x8	1
113	99.3175.00	Vite M8x60 UNI 5931	8
114	96.7014.00	Rosetta Ø 8,4x13x0,8	12
115	44.1200.41	Testata pompa - M13-180 M17-130	
	44.1201.41	Testata pompa - M15-150 M961	
	44.1204.41	Testata pompa - M14-120	
	44.1205.41	Testata pompa - M12-140 M960	
116	96.7514.00	Rosetta Ø 21,5x27x1,5	1
117	98.2176.00	Tappo G 1/2"x10	1
118	90.1614.00	Anello rad. Ø 20x30x5	23
119	96.7380.00	Rosetta Ø 17,5x23x1,5	1
120	98.2100.00	Tappo G 3/8"x13	1
121	51.1000.51	Anello di testa Ø 15	90-130
	44.1001.51	Anello di testa Ø 18	129-131
122	90.2620.00	Anello ten. alt. Ø15x25x5/3,1 HP	88-130
	90.2682.00	Anello ten. alt. Ø 18x30x6/3,5 HP	127-131
123	90.2622.00	Anello RESTOP Ø 15x25x5/3,1	88-130
	90.2683.00	Anello RESTOP Ø 18x30x6/3,5	127-131
124	52.2166.70	Anello intermedio Ø 15	89-130
	44.2161.70	Anello intermedio Ø 18	128-131
125	44.0800.70	Anello di fondo Ø 15	125-130
	44.0801.70	Anello di fondo Ø 18	126-131
126	90.3612.00	OR Ø 31,47x1,78	125-126-130-131

POS	COD.	DESCRIZIONE - DESCRIPTION - KIT	NR
64	43.2127.51	Pressa cavo	2
65	10.7273.01	Cavo 5,8 m.	1
66	93.5790.00	Morsetto - 380 V	1
67	93.5179.00	Interruttore magnetotermico - 380-415 V	1
	93.5182.00	Interruttore magnetotermico - 220-240 V	
68	43.2120.51	Mascherina interruttore	1
69	43.2119.47	Membrana interruttore	1
70	43.2113.51	Copri basetta	1
71	99.1720.00	Vite M5x70 UNI 5931	4
72	99.0744.00	Vite Ø 3x16 autofilante	4
73	99.1540.00	Vite M5x12 UNI 7688	2
74	99.1515.00	Vite M5x12 UNI 7687	1
75	96.6913.00	Rosetta Ø 5,3x9x0,6	1
76	91.8372.00	Cuscinetto a sfere 6206	1
77	90.0850.00	Anello seeger Ø 62 UNI 7437	1
79	42.0300.51	Ventola	1
80	43.0400.51	Copri ventola	1
81	90.0655.00	Anello seeger Ø 28 UNI 7435	1
82	99.1658.00	Vite M5x45 UNI 7687	4
83	90.3863.00	OR Ø 28,25x2,62 (3112)	1
84	98.2173.00	Tappo G 1/2"x10	1
85	99.1867.00	Vite M6x18 UNI 5931	4
86	96.6938.00	Rosetta Ø 6,4x10x0,7	8
87	99.1897.00	Vite M6x25 UNI 5931	4
88	10.0076.66	Ugello - Nozzle Ø 2,5 (12÷17 l/min.)	1
89	90.3832.00	OR Ø 13,95x2,62 (3056)	94
90	10.0078.70	Nipplo G 3/8" con Ø 3 - STANDARD	1
	10.0147.70	Nipplo M22x1,5 con Ø 3	
91	90.3582.00	OR Ø 9,25x1,78 (2037)	94
92	94.8217.00	Molla conica Ø 4,37-3x11	94
93	97.4782.00	Sfera Ø 7/32"	94
95	36.2563.70	Sede valvola	1

**VERSIONE CON TOTALSTOP – TOTALSTOP VERSION
VERSION AVEC LE TOTALSTOP – VERSION MIT TOTALSTOP
VERSIÓN CON EL TOTALSTOP – VERSÃO COM TOTALSTOP**

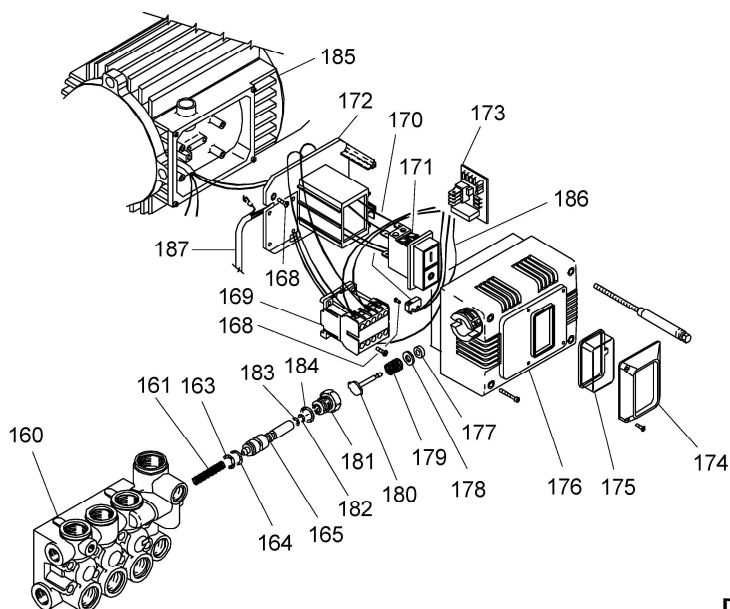

DIS. COD. 44.9528.00

POS	COD.	DESCRIZIONE – DESCRIPTION - KIT	NR
160	44.1210.41	Testata pompa Ø 15	1
	44.1211.41	Testata pompa Ø 18	1
161	94.7341.00	Molla Ø 7.5x37.5	1
163	90.5052.00	Anello antiest. Ø 9.13x14x1.5	306 1
164	90.3819.00	OR Ø 9.13x2.62 (109)	306 1
165	10.0799.70	Pistoncino di comando	306 1
168	99.1450.00	Vite Ø 4.2x16 autofilettante	5
169	93.6340.00	Mini contattore 400-415 V	1
	93.6342.00	Mini contattore 230-240 V	1
170	10.7366.02	Cablaggio mini interruttore	1
171	93.5189.00	Interruttore termico bipolare 400-415 V	1
	93.5191.00	Interruttore termico bipolare 230-240 V	1
172	43.2121.51	Piastra fissaggio interruttore	1
173	93.6415.00	Scheda termica temporizz. 400-145 V	1
	93.6430.00	Scheda termica temporizz. 230-240 V	1
174	43.2123.51	Mascherina interruttore	1
175	43.2122.47	Membrana interruttore	1

POS	COD.	DESCRIZIONE – DESCRIPTION - KIT	NR
176	43.2114.51	Copri basetta	1
177	90.2532.00	Anello di tenuta Ø 6.32x12.7x3.96	1
178	96.7035.00	Rosetta Ø 8.4x17x1.6	1
179	94.7412.00	Molla Ø 13x30	1
180	43.2126.51	Pistoncino di comando	1
181	10.0800.70	Guida pistone Totalstop	306 1
182	90.5020.00	Anello antiest. Ø 5.2x8x1.5	306 1
183	90.3570.00	OR Ø 4.48x1.78 (2018)	306 1
184	90.3591.00	OR Ø 14x1.78 (2056)	306 1
185	43.3232.02	Statore comp. 4 CV – Tri. - 400V 50 HZ	1
	43.3233.02	Statore comp. 4 CV – Tri. - 230V 50 HZ	1
	43.3269.02	Statore comp. 5.5 CV – Tri. - 230V 60 HZ	1
	43.3270.02	Statore comp. 5.5 CV – Tri. - 400V 60 HZ	1
	43.3250.02	Statore comp. 5 CV – Tri. - 230V 60 HZ	1
	43.3262.02	Statore comp. 5.5 CV – Tri. - 400V 50 HZ	1
43.3263.02	Statore comp. 5.5 CV – Tri. - 230V 50 HZ	1	
186	10.7364.01	Cablaggio interruttore	1
187	10.7368.01	Cavo 5.8 m.	1

KIT Nr.	KIT 306
Posizioni include Postions included	163 – 164 – 165 181 – 182 – 183 - 184
Nr. Pcs.	1

**DIMENSIONI D'INGOMBRO – OVERALL DIMENSIONS – DIMENSIONS D'ENCOMBREMENT
 RAUMBEDARF – DIMENSIONES TOTALES – DIMENSÕES**

MONOFASE – SINGLEPHASE – MONOPHASE – WECHSELSTROM – MONOFÁSICA – MONOFÁSICO

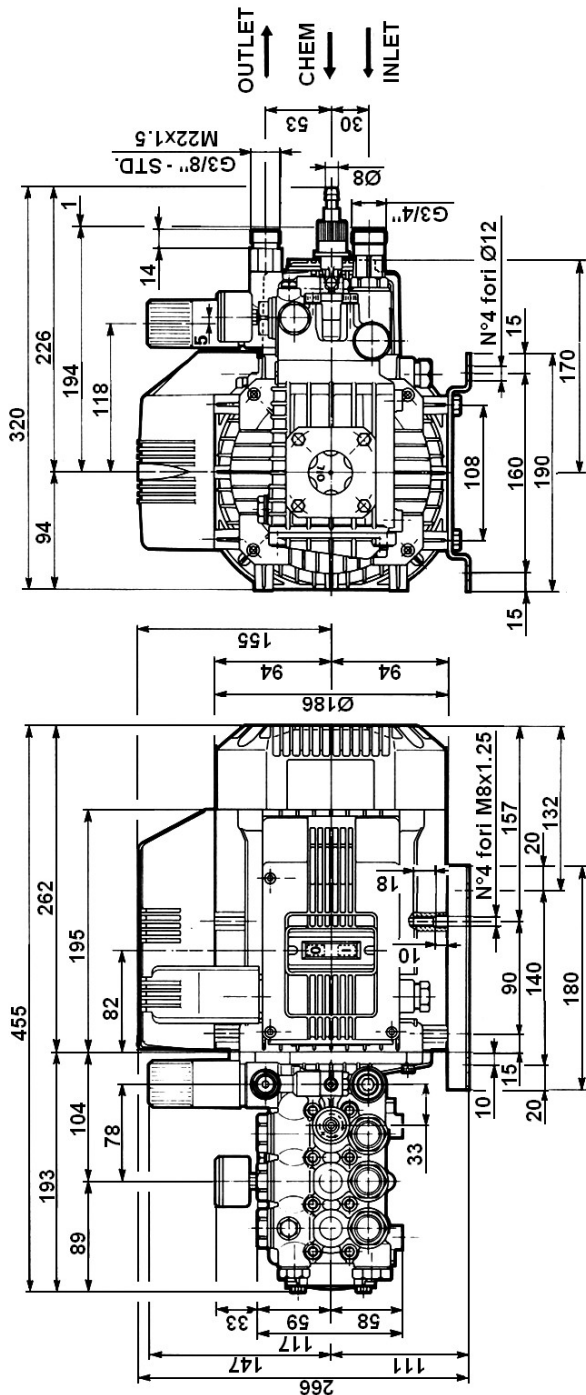

COD. DIS. 44.2152.00

DIMENSIONI D'INGOMBRO – OVERALL DIMENSIONS – DIMENSIONS D'ENCOMBREMENT
 RAUMBEDARF – DIMENSIONES TOTALES – DIMENSÕES

TRIFASE – THREEPHASE – TRIPHASE – DREHSTROM – TRIFÁSICA – TRIFÁSICO

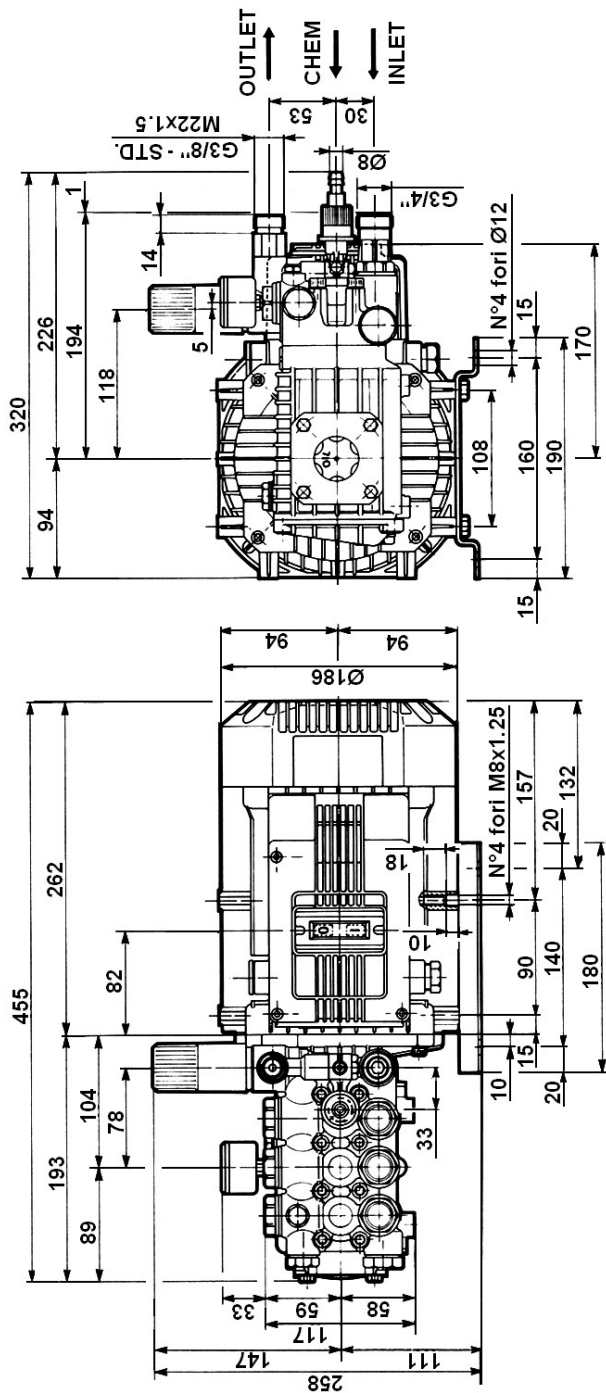

COD. DIS. 44.2151.00

1 - CAMBIO OLIO

- 1.1 – Il cambio dell'olio va eseguito con pompa a temperatura di lavoro.
- 1.2 – Posizionare un recipiente sotto il tappo di scarico olio (3).
- 1.3 – Rimuovere il tappo con asta (1) e successivamente il tappo di scarico (3).
- 1.4 – Attendere fino a quando tutto l'olio è uscito, quindi riavvitare il tappo di scarico (3) con la coppia torcente indicata su disegno esploso.
- 1.5 – Riempire con olio nuovo fino al raggiungimento della mezzeria del tappo spia livello olio (2) e riavvitare il tappo con asta (1) .

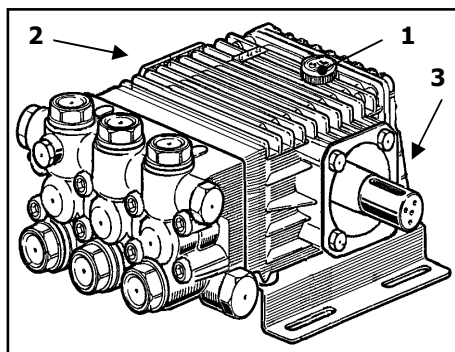

Per il tipo di olio da utilizzare fare riferimento a quanto indicato sul libretto generico.



ATTENZIONE: L'olio esausto deve essere raccolto in recipienti e smaltito negli appositi centri in accordo alla normativa vigente. Non deve essere assolutamente disperso nell'ambiente.

1 – OIL CHANGING

- 1.1 – Oil changing must be done with the pump at operating temperature.
- 1.2 – Put a container under the oil drain plug (3).
- 1.3 – Remove the oil dipstick (1) and then the drain plug (3).
- 1.4 – Wait until all the oil has drained out, then screw the drain plug (3) and tighten at the torque shown in the exploded diagram.
- 1.5 – Fill with new oil until the middle of the oil level indicator (2) is reached, screw by hand the oil dipstick (1).

Refer to the generic booklet for the type of oil to use.



WARNING: The exhaust oil must be collected in receptacles and disposed of at authorised centres as specified by law. It must not be thrown away in the environment.

1 - CHANGEMENT DE L'HUILE

- 1.1 – Le changement de l'huile doit être exécuté avec la pompe à température d'exercice.
- 1.2 – Placer un récipient sous le bouchon de vidange de l'huile (3).
- 1.3 – Enlever le bouchon-jauge (1), puis enlever le bouchon de vidange (3).
- 1.4 – Attendre que toute l'huile soit sortie, puis revisser le bouchon de vidange (3) avec le couple de torsion qui est indiqué sur le dessin éclaté.
- 1.5 – Remplir avec de l'huile neuve jusqu'à la ligne médiane du bouchon indicateur du niveau d'huile (2), et revisser le bouchon-jauge (1).

Pour le type d'huile à utiliser, se référer à ce qui est indiqué sur la notice générale.



ATTENTION : L'huile usée doit être recueillie dans des récipients et éliminée dans les centres prévus à cet effet, conformément à la réglementation en vigueur. Il ne faut absolument pas la jeter dans l'environnement.

1 - ÖLWECHSEL

- 1.1 – Beim Ölwechsel muss die Pumpe Betriebstemperatur aufweisen.
- 1.2 – Unter den Ölablassverschluss (3) einen Behälter stellen.
- 1.3 – Den Verschluss mit dem Stab (1) und danach den Ablassverschluss (3) abnehmen.
- 1.4 – Warten, bis das gesamte Öl abgelassen ist und den Ablassverschluss (3) mit dem auf der Übersichtszeichnung angegebenen Drehmoment wieder anschrauben.
- 1.5 – Mit frischem Öl füllen, bis die Mittellinie des Ölstandkontrollverschlusses (2) erreicht ist und den Verschluss mit dem Stab (1) wieder anschrauben.

Bezüglich der verwendbaren Ölsorten siehe die Angaben im allgemeinen Handbuch.



ACHTUNG: Das Altöl muss in Behältern gesammelt und gemäß den geltenden Vorschriften bei den hierfür vorgesehenen Zentren entsorgt werden. Es darf keinesfalls umweltschädigend entsorgt werden.

1 - CAMBIO DE ACEITE

- 1.1 – El cambio de aceite se efectúa con bomba a temperatura de trabajo.
- 1.2 – Colocar un recipiente debajo del tapón de descarga de aceite (3).
- 1.3 – Extraer el tapón con varilla (1) y seguidamente el tapón de descarga (3).
- 1.4 – Esperar hasta que haya salido todo el aceite, volver a enroscar el tapón de descarga (3) con el par de torsión indicado en el despiece.
- 1.5 – Llenar con aceite nuevo hasta alcanzar la línea media del tapón indicador de nivel de aceite (2) y volver a enroscar el tapón con varilla (1).

Para el tipo de aceite que debe utilizarse, remitirse a las indicaciones del manual general.



ATENCIÓN: El aceite residual debe recogerse en recipientes y eliminarse en los centros pertinentes de acuerdo con la normativa vigente. En ningún caso debe dispersarse en el ambiente.

1 - TROCA DE ÓLEO

- 1.1 – A troca de óleo deve ser feita com a bomba na temperatura de trabalho.
- 1.2 – Posicionar um recipiente embaixo da tampa de descarga de óleo (3).
- 1.3 – Remover a tampa com o pino (1) e, em seguida, a tampa de descarga (3).
- 1.4 – Esperar que todo o óleo saia, recolocar a tampa de descarga (3) com o binário de torção indicado no desenho explodido.
- 1.5 – Encher com o óleo novo até chegar na linha da tampa de controle do nível do óleo (2) e recolocar a tampa com o pino (1).

Para o tipo de óleo a ser utilizado, consultar as indicações do livro genérico.



ATENÇÃO: O óleo consumido deve ser coletado em recipientes e eliminado nos locais adequados, de acordo com a normativa vigente. Não deve, de modo algum, ser jogado no ambiente.

**SCHEMA ELETTRICO – ELECTRICAL DRAWING – SCHÉMA ÉLECTRIQUE
ELEKTRISCHE ZEICHNUNG – DIBUJO ELÉCTRICO - DESENHO ELÉTRICO**

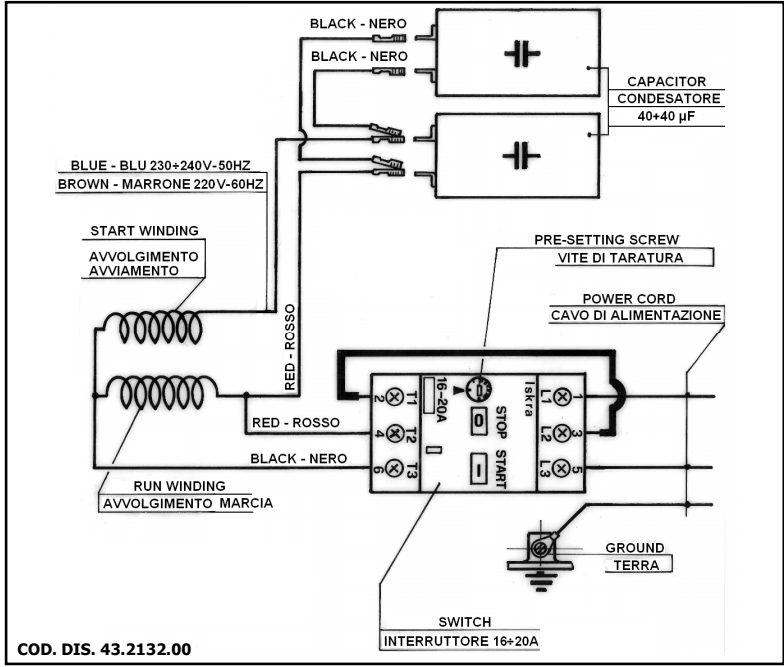

COD. DIS. 43.2132.00

**MONOFASE
SINGLEPHASE
MONOPHASE
WECHSELSTROM
MONOFÀSICA
MONOFÀSICO**

**10/130 – 12/100
951 – 954 - 957**

**SCHEMA ELETTRICO – ELECTRICAL DRAWING – SCHÉMA ÉLECTRIQUE
ELEKTRISCHE ZEICHNUNG – DIBUJO ELÉCTRICO - DESENHO ELÉTRICO**

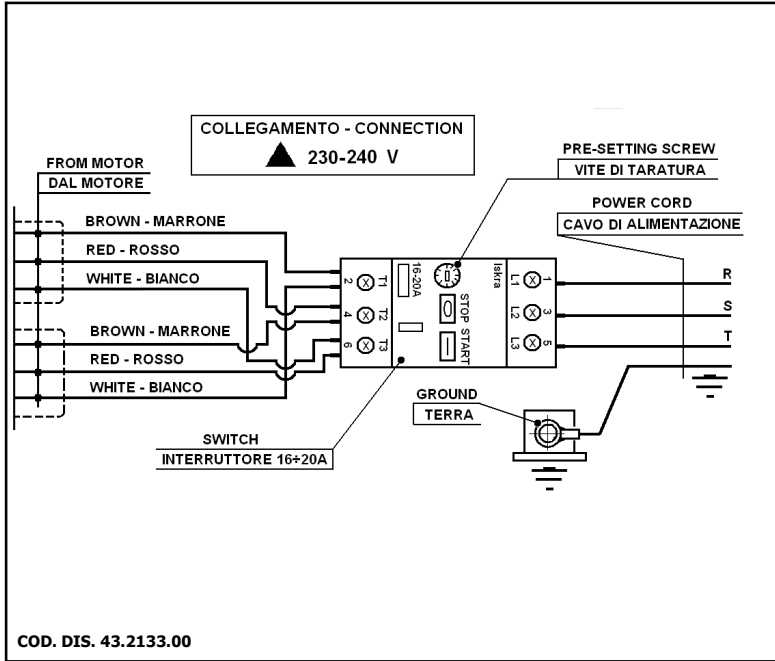

**TRIFASE
THREEPHASE
TRIPHAS
DREHSTROM
TRIFÀSICA
TRIFÀSICO**

**12/140 – 13/180
14/120 – 15/150
17/130
961 - 960**

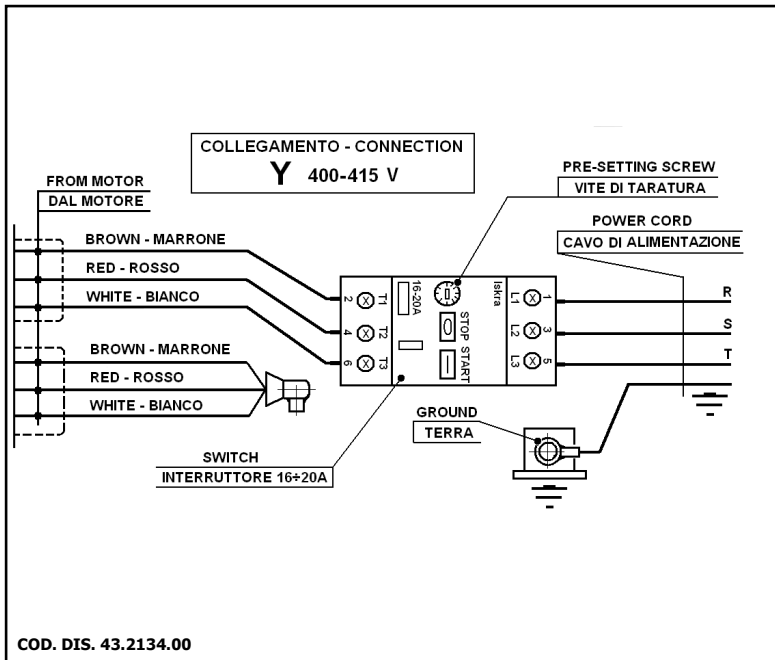

**TRIFASE
THREEPHASE
TRIPHAS
DREHSTROM
TRIFÀSICA
TRIFÀSICO**

**12/140 – 13/180
14/120 – 15/150
17/130
961 - 960**

**SCHEMA ELETTRICO – ELECTRICAL DRAWING – SCHÉMA ÉLECTRIQUE
ELEKTRISCHE ZEICHNUNG – DIBUJO ELÉCTRICO - DESENHO ELÉTRICO**

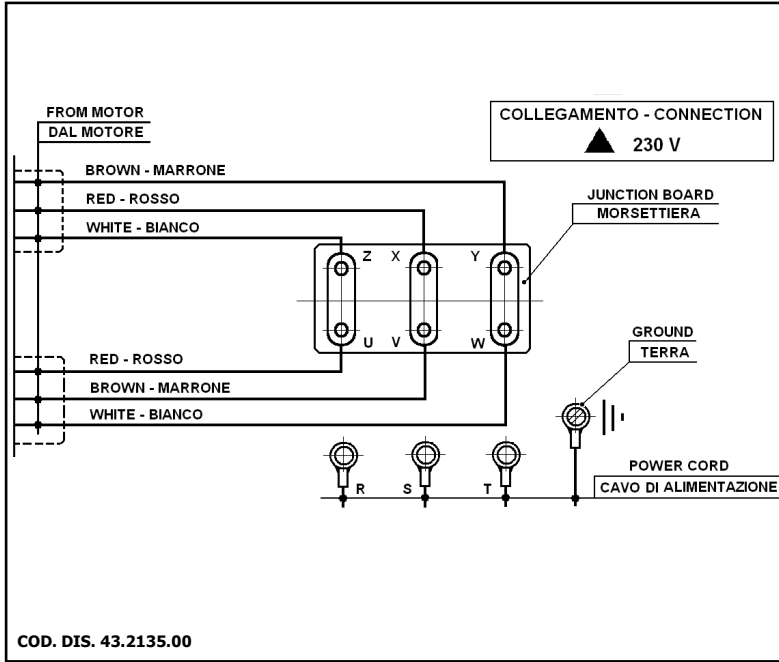

**TRIFASE
THREEPHASE
TRIPHASE
DREHSTROM
TRIFÀSICA
TRIFÁSICO**

**12/140 – 13/180
14/120 – 15/150
17/130
961 - 960**

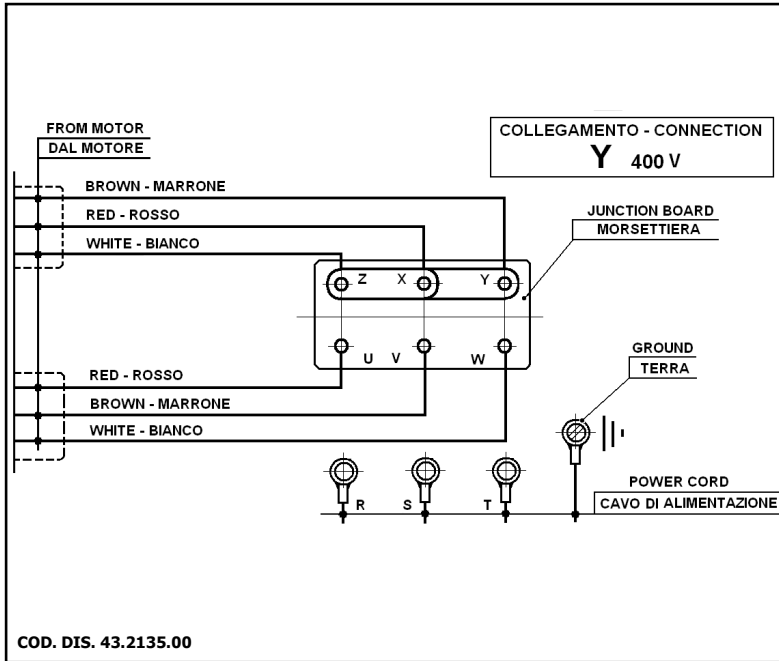

**TRIFASE
THREEPHASE
TRIPHASE
DREHSTROM
TRIFÀSICA
TRIFÁSICO**

**12/140 – 13/180
14/120 – 15/150
17/130
961 - 960**

**SCHEMA ELETTRICO – ELECTRICAL DRAWING – SCHÉMA ÉLECTRIQUE
ELEKTRISCHE ZEICHNUNG – DIBUJO ELÉCTRICO - DESENHO ELÉTRICO**

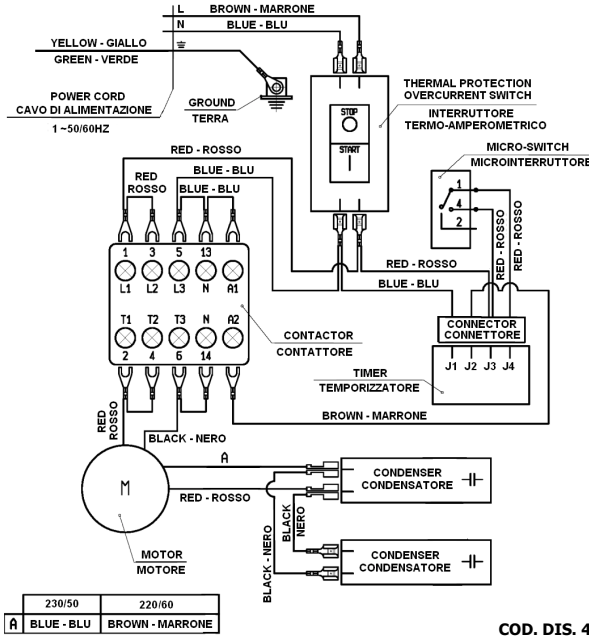

COD. DIS. 43.2154.00

TOTALSTOP
220V 60HZ
230V 50HZ

**MONOFASE
SINGLEPHASE
MONOPHASE
WECHSELSTROM
MONOFÁSICA
MONOFÁSICO**

10/130 – 12/100
951 – 954 - 957

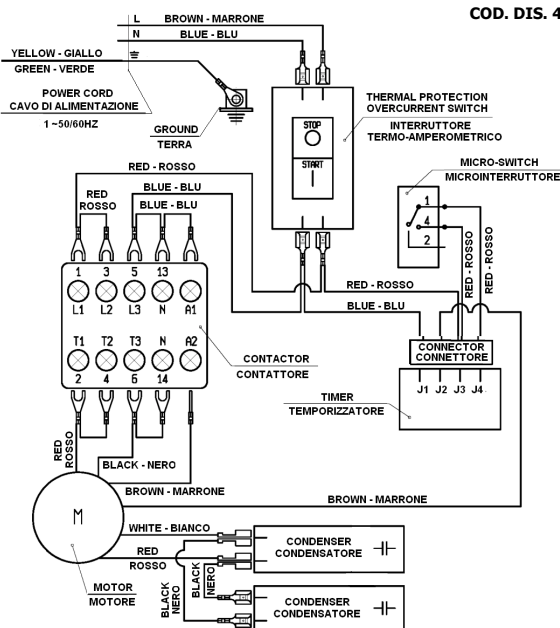

COD. DIS. 43.2153.00

TOTALSTOP
240V 50HZ

**MONOFASE
SINGLEPHASE
MONOPHASE
WECHSELSTROM
MONOFÁSICA
MONOFÁSICO**

10/130 – 12/100

**SCHEMA ELETTRICO – ELECTRICAL DRAWING – SCHÉMA ÉLECTRIQUE
ELEKTRISCHE ZEICHNUNG – DIBUJO ELÉCTRICO - DESENHO ELÉTRICO**

COD. DIS. 43.2155.00

TOTALSTOP

**TRIFASE
THREEPHASE
TRIPHASE
DREHSTROM
TRIFÀSICA
TRIFÁSICO**

**12/140 – 13/180
14/120 – 15/150
17/130
961 - 960**

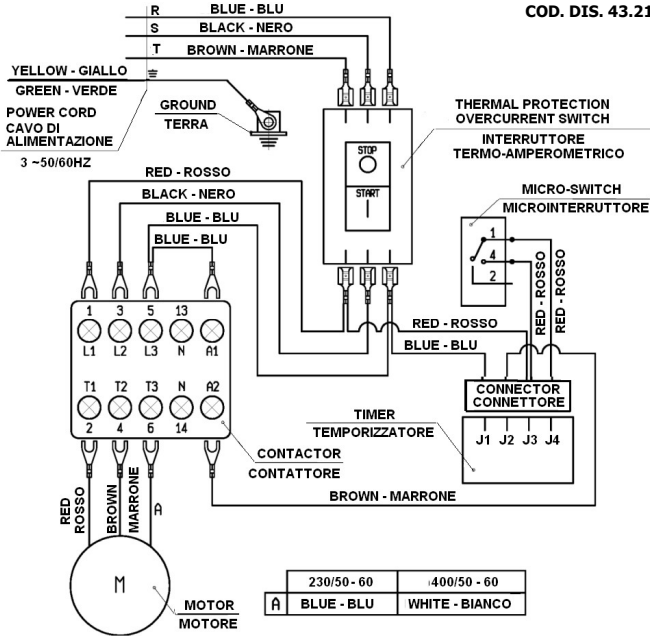

DICHIARAZIONE DI CONFORMITÀ

(Ai sensi dell'allegato II della Direttiva Europea 2006/42/CE).

Il produttore **INTERPUMP GROUP S.p.A.** – Via E. Fermi, 25 – 42049 S.ILARIO D'ENZA (RE) - Italia

DICHIARA sotto la propria esclusiva responsabilità che la macchina identificata e descritta come segue :

Tipo macchina : Motopompa per acqua ad alta pressione

Marchio di fabbrica : INTERPUMP GROUP

Modello : M10/130 – M12/100 – M951 – M951 – M957 – M12/140 – M13/180 – M14/120 – M15/150
M17/130 – M960 – M961 (per idropulitrici – categoria AEE elettrodomestico).

Risulta essere conforme ai requisiti delle sotto elencate direttive e successivi aggiornamenti :

- Direttiva Macchine 2006/42/CE.

- Direttiva sulla bassa tensione 2006/95/CE.

- Direttiva sulla compatibilità elettromagnetica 2004/108/CE.

- Direttiva sulla restrizione dell'uso di determinate sostanze pericolose nelle apparecchiature elettriche ed elettroniche 2011/65/UE – RoHS.

L'attrezzatura non contiene sostanze con restrizioni d'uso in concentrazione maggiore di quelle elencate nell'allegato II ad eccezione delle applicazioni esentate dalle restrizioni elencate nell'allegato III.

- Direttiva sui rifiuti di apparecchiature elettriche ed elettroniche 2002/96/CE.

- Direttiva sulle emissioni acustiche ambientali 2000/14/CE.

Valutazione della conformità di cui allegato V.

Potenza sonora : $L_w = 93$ dB(A) – Potenza sonora garantita : $L_w = 94$ dB(A)

Il fabbricante, mediante accorgimenti aziendali, garantisce che tutte le macchine prodotte siano conformi a quanto dichiarato.

Norme applicate : UNI EN ISO 12100:2010 - UNI EN 809:2000

Persona autorizzata a costituire il fascicolo tecnico : Nome : Maurizio Novelli

Indirizzo : INTERPUMP GROUP S.p.A. – Via E. Fermi, 25 – 42049 S. ILARIO D'ENZA (RE) – Italia

Persona autorizzata a redigere la dichiarazione : L'amministratore delegato Ing. Paolo Marinsek

Reggio Emilia 03/2013

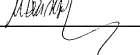
Firma 

EC DECLARATION OF CONFORMITY

(In accordance with Annex II of European Directive 2006/42/CE).

The manufacturer **INTERPUMP GROUP S.p.A.** – Via E. Fermi, 25 – 42049 S.ILARIO D'ENZA (RE) - Italy **DECLARES** under sole responsibility that the machine identified and described as follows :
Machine type : Motor pump for high pressure water
Trademark : INTERPUMP GROUP
Model : M10/130 – M12/100 – M951 – M951 – M957 - M12/140 – M13/180 – M14/120 – M15/150
M17/130 – M960 – M961 (for pressure washers – EEE category: household appliance).

complies with the requirements of the directives listed below and subsequent updates :

- Machinery Directive 2006/42/CE.
- Low Voltage Directive 2006/95/EC.
- Electromagnetic compatibility Directive 2004/108/EC.
- Directive 2011/65/EU – RoHS on the restriction of the use of certain hazardous substances in electrical and electronic equipment.

The equipment does not contain more than the specified concentrations of restricted substances listed in Annex II except for the applications exempted from the restriction listed in Annex III.

- Directive 2002/96/EC on waste electrical and electronic equipment.
- Directive 2000/14/EC on noise emission in the environment.

Conformity evaluation pursuant to Annex V.

Sound power : $L_w = 93 \text{ dB(A)}$ – Guaranteed sound power : $L_w = 94 \text{ dB(A)}$.

The manufacturer, through company measures, guarantees that all machinery manufactured conform to what has been declared.

Standards applied : UNI EN ISO 12100:2010 - UNI EN 809:2000

Person authorised to compile the technical file :

Name : Maurizio Novelli

Address : INTERPUMP GROUP S.p.A. – Via E. Fermi, 25 – 42049 S. ILARIO D'ENZA (RE) – Italy

Person authorized to draw up the declaration :

CEO Mr. Paolo Marinsek

Reggio Emilia 03/2013

Signature



DÉCLARATION DE CONFORMITÉ CE

(Conformément à l'annexe II de la Directive Européenne 2006/42/CE).

Le fabricant **INTERPUMP GROUP S.p.A.** – Via E. Fermi, 25 – 42049 S.ILARIO D'ENZA (RE) - Italie

DÉCLARE sous sa seule responsabilité que la machine identifiée et décrite comme suit :

Type de machine : Motopompe d'eau à haute pression

Marque de fabrique : INTERPUMP GROUP

Modèle : M10/130 – M12/100 – M951 – M951 – M957 - M12/140 – M13/180 – M14/120 – M15/150

M17/130 – M960 – M961 (pour nettoyeurs à haute pression - catégorie d'appareils AEE).

Est conforme aux spécifications des directives énumérées ci-dessous et mises à jour suivantes :

- Directive Machines 2006/42/CE.
- Directive de basse tension 2006/95/CE.
- Directive de compatibilité électromagnétique 2004/108/CE.
- Directive relative à la limitation de l'utilisation de certaines substances dangereuses dans les équipements électriques et électroniques 2011/65/UE – RoHS.

L'équipement ne contient pas de substances assorties de restrictions concernant l'utilisation en concentration plus élevée que celles énumérées à l'annexe II, sauf pour des applications exemptées des restrictions énumérées à l'annexe III.

- Directive 2002/96/CE sur les déchets d'équipements électriques et électroniques.
 - Directive 2000/14/CE sur le bruit ambiant.
- Évaluation de la conformité à l'annexe V.

Puissance sonore : $L_w = 93 \text{ dB(A)}$ – Puissance sonore garantie : $L_w = 94 \text{ dB(A)}$

Le fabricant, par des accords d'entreprise, veille à ce que toutes les machines produites soient conformes à ce qui est déclaré.

Normes appliquées : UNI EN ISO 12100:2010 - UNI EN 809:2000

Personne autorisée à réaliser le manuel technique : Nom : Maurizio Novelli

Adresse : INTERPUMP GROUP S.p.A. – Via E. Fermi, 25 – 42049 S. ILARIO D'ENZA (RE) – Italie

Personne autorisée à rédiger la déclaration : L'administrateur délégué Ing. Paolo Marinsek

Reggio Emilia 03/2013

Signature



KONFORMITÄTSERKLÄRUNG

(gemäß Anhang II der Europäischen Richtlinie 2006/42/EG).

Der Hersteller **INTERPUMP GROUP S.p.A.** – Via E. Fermi, 25 – 42049 S.ILARIO D'ENZA (RE) – Italien
ERKLÄRT auf alleinige Verantwortung, dass die wie folgt bezeichnete und beschriebene Maschine :
Maschinentyp: Motorpumpe für Hochdruckwasser
Herstellermarke : INTERPUMP GROUP
Modell : M10/130 – M12/100 – M951 – M951 – M957 - M12/140 – M13/180 – M14/120 – M15/150
M17/130 – M960 – M961 (für Hochdruckreiniger – Kategorie: elektronische und elektromechanische
Haushaltsgeräte).

mit den nachstehend aufgelisteten Richtlinien und ihren nachfolgenden Aktualisierungen konform ist :

- Maschinenrichtlinie 2006/42/EG.
- Niederspannungsrichtlinie 2006/95/EG.
- Richtlinie 2004/108/EG über die elektromagnetische Verträglichkeit.
- Richtlinie zur Beschränkung der Verwendung bestimmter gefährlicher Stoffe in Elektro- und Elektronikgeräten 2011/65/EU - RoHS.

Das Gerät enthält keine Stoffe, für die Beschränkungen bezüglich ihrer Verwendung in Konzentrationen bestehen, die über denen im Anhang II liegen, mit Ausnahme von Anwendungen, die von den im Anhang III aufgeführten Beschränkungen ausgenommen sind.

- Richtlinie 2002/96/EG über Elektro- und Elektronik-Altgeräte.
- Richtlinie 2000/14/EG über umweltbelastende Geräuschemissionen .
Bewertung der Konformität nach Anhang V.

Schalleistung : $L_w = 93$ dB(A) – Garantierte Schalleistung : $L_w = 94$ dB(A)

Der Hersteller garantiert mittels unternehmensinterner Maßnahmen, dass alle produzierten Maschinen mit der vorliegenden Erklärung konform sind.

Angewandte Normen : UNI EN ISO 12100:2010 - UNI EN 809:2000

Person, die bevollmächtigt ist, die relevanten technischen Unterlagen zusammenzustellen : Maurizio Novelli

Adresse : INTERPUMP GROUP S.p.A. – Via E. Fermi, 25 – 42049 S. ILARIO D'ENZA (RE) – Italien

Person, die zur Ausstellung dieser Erklärung bevollmächtigt ist : Der Geschäftsführer Ing. Paolo Marinsek

Reggio Emilia 03/2013

Unterschrift



DECLARACIÓN DE CONFORMIDAD

(De acuerdo con el anexo II de la Directiva Europea 2006/42/CE).

El fabricante **INTERPUMP GROUP S.p.A.** – Via E. Fermi, 25 – 42049 S.ILARIO D'ENZA (RE) – Italia **DECLARA** bajo su propia y exclusiva responsabilidad a la máquina identificada y descrita del siguiente modo :

Tipo de máquina : Bomba alternativa para agua de alta presión

Marca del fabricante : INTERPUMP GROUP

Modelo : M10/130 – M12/100 – M951 – M951 – M957 - M12/140 – M13/180 – M14/120 – M15/150

M17/130 – M960 – M961 (para hidro-limpiadoras- categoría AEE electrodoméstico).

Resulta ser conforme con las directivas que se indican a continuación y con sus sucesivas actualizaciones :

- Directiva de Máquinas 2006/42/CE.
- Directiva sobre la baja tensión 2006/95/CE.
- Directiva sobre la compatibilidad electromagnética 2004/108/CE.
- Directiva acerca de la restricción del uso de determinadas sustancias peligrosas en máquinas eléctricas y electrónicas 2011/65/UE - RoHS.

La máquina no contiene sustancias con restricción de uso en concentración mayor de aquellas citadas en el anexo II, exceptuando las aplicaciones exentas de las restricciones citadas en el anexo III.

- Directiva sobre desechos de aparatos eléctricos y electrónicos 2002/96/CE.
- Directiva sobre emisiones acústicas ambientales 2000/14/CE.

Valoración de la conformidad contenida en el anexo V.

Potencia sonora : $L_w = 93 \text{ dB(A)}$ – Potencia sonora garantizada : $L_w = 94 \text{ dB(A)}$

El fabricante, a través de medidas tomadas por la empresa, garantiza que todas las máquinas fabricadas cumplen con todo lo declarado con anterioridad.

Normas aplicadas : UNI EN ISO 12100:2010 - UNI EN 809:2000

Persona autorizada a realizar el fascículo técnico : Nombre : Maurizio Novelli

Dirección : INTERPUMP GROUP S.p.A. – Via E. Fermi, 25 – 42049 S. ILARIO D'ENZA (RE) – Italia

Persona autorizada a redactar la declaración : El administrador delegado Ing. Paolo Marinsek

Reggio Emilia 03/2013

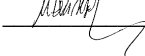
Firma 

DECLARAÇÃO CE DE CONFORMIDADE **(Nos termos do anexo II da Directiva Europeia 2006/42/CE).**

O fabricante **INTERPUMP GROUP S.p.A.** – Via E. Fermi, 25 – 42049 S.ILARIO D'ENZA (RE) – Itália
DECLARA sob a sua exclusiva responsabilidade que a máquina identificada e descrita tal como se segue :
Tipo de máquina : Motobomba para água a alta pressão
Marca de fábrica : INTERPUMP GROUP
Modelo : M10/130 – M12/100 – M951 – M951 – M957 - M12/140 – M13/180 – M14/120 – M15/150
M17/130 – M960 – M961 (para máquinas de limpeza por jacto de água a alta pressão - categoria AEE
electrodoméstico).

Está em conformidade com as directivas abaixo indicadas e posteriores actualizações :

- Directiva Máquinas 2006/42/CE.
- Directiva sobre a baixa tensão 2006/95/CE.
- Directiva sobre a compatibilidade electromagnética 2004/108/CE.
- Directiva sobre a restrição de uso de determinadas substâncias perigosas em aparelhos eléctricos e electrónicos 2011/65/UE - RoHS.

O equipamento não contém substâncias com restrições de uso em concentração superior às indicadas no anexo II, à excepção das aplicações isentas pelas restrições indicadas no anexo III.

- Directiva sobre os resíduos de aparelhos eléctricos e electrónicos 2002/96/CE.
- Directiva sobre as emissões acústicas ambientais 2000/14/CE.

Avaliação da conformidade, de acordo com o anexo V.

Potência acústica : $L_w = 93$ dB(A) – Potência acústica garantida : $L_w = 94$ dB(A)

O fabricante, mediante disposições da empresa, garante que todas as máquinas produzidas estão em conformidade com as declarações.

Normas aplicadas : UNI EN ISO 12100:2010 - UNI EN 809:2000

Pessoa autorizada a compilar a documentação técnica : Nome : Maurizio Novelli

Morada : INTERPUMP GROUP S.p.A. – Via E. Fermi, 25 – 42049 S. ILARIO D'ENZA (RE) – Itália

Pessoa autorizada a redigir a declaração : O administrador delegado Eng.º Paolo Marinsek

Reggio Emilia 03/2013

Assinatura



COPYRIGHT Il contenuto di questo libretto è di proprietà di INTERPUMP GROUP, ne è vietata la riproduzione e/o la divulgazione, anche parziale, a termini di legge.

COPYRIGHT The contents of this booklet are the property of INTERPUMP GROUP. Reproduction and divulgation, in whole or in part, are prohibited by law.

COPYRIGHT Le contenu de cette notice appartient à INTERPUMP GROUP : aux termes de la loi il est interdit de le reproduire et/ou de le divulguer, même partiellement.

COPYRIGHT Der Inhalt dieser Bedienungsanleitung ist Eigentum von INTERPUMP GROUP. Die auch nur teilweise Reproduktion und/oder Verbreitung ist gesetzlich verboten.

COPYRIGHT El contenido del presente manual es propiedad de INTERPUMP GROUP y está legalmente prohibida su reproducción y/o divulgación parcial o total.

COPYRIGHT O conteúdo deste livro é de propriedade da INTERPUMP GROUP, e é proibida a sua reprodução e/ou a sua divulgação, mesmo parcial, nos termos da lei.

Le informazioni presenti su questo documento possono essere variate senza preavviso.

The information contained in this document may change without notice.

Les informations présentes sur ce document peuvent être changées sans besoin de préavis.

Die in diesem Dokument enthaltenen Informationen können ohne Vorankündigung geändert werden.

La información contenida en el presente documento puede modificarse sin previo aviso.

As informações contidas neste documento poderão ser sujeitas a alterações sem aviso prévio.



**INTERPUMP
GROUP**

**AZIENDA CON SISTEMA
DI GESTIONE QUALITÀ
CERTIFICATO DA DNV
= ISO 9001 =**

VIA FERMI, 25 42049 S.ILARIO – REGGIO EMILIA (ITALY)
TEL. +39 – 0522 - 904311 TELEFAX +39 – 0522 – 904444
E-mail: info@interpumpgroup.it - <http://www.interpumpgroup.it>