

Caratteristiche Tecniche **AQUAGROUP PXI 2020** *Technical Characteristics*

Pump Pompa	Pressure Pressione		Volume Portata				RPM giri/min		Power Potenza			
			l/min		GPM				HP		kW	
	bar	PSI	50 Hz	60 Hz	50 Hz	60 Hz	50 Hz	60 Hz	50 Hz	60 Hz	50 Hz	60 Hz
AQU1550IR	500	7250	15.1	18.1	4.0	4.8	1450	1740	19.4	23.3	14.3	17.2

Dimensioni d'ingombro

Overall dimensions

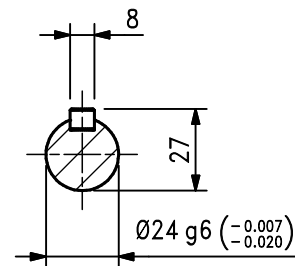
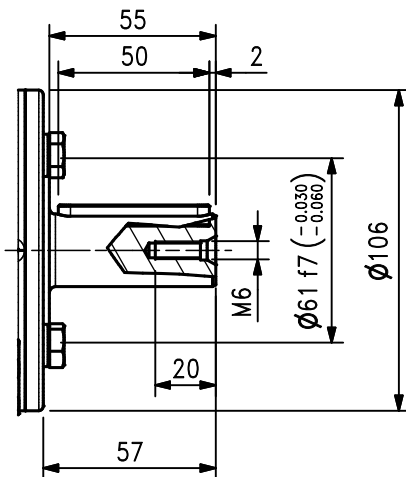
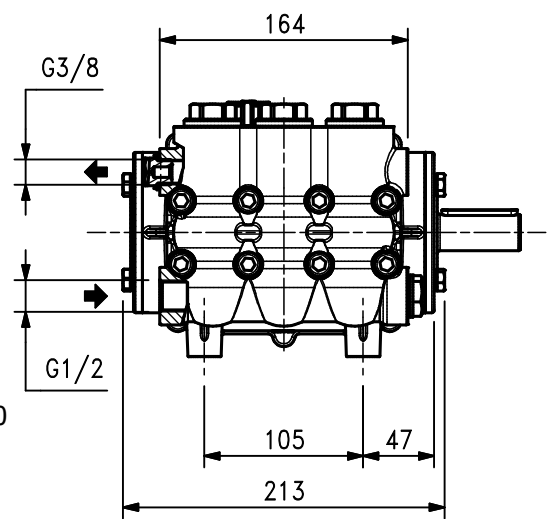
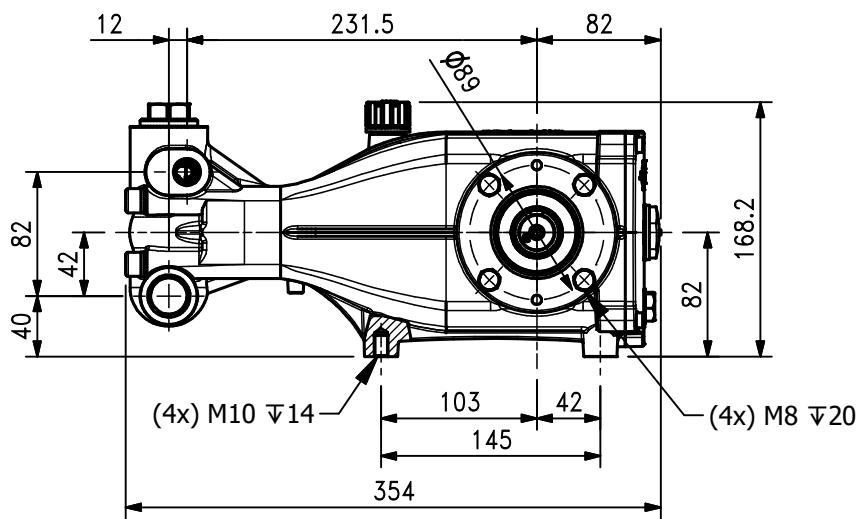

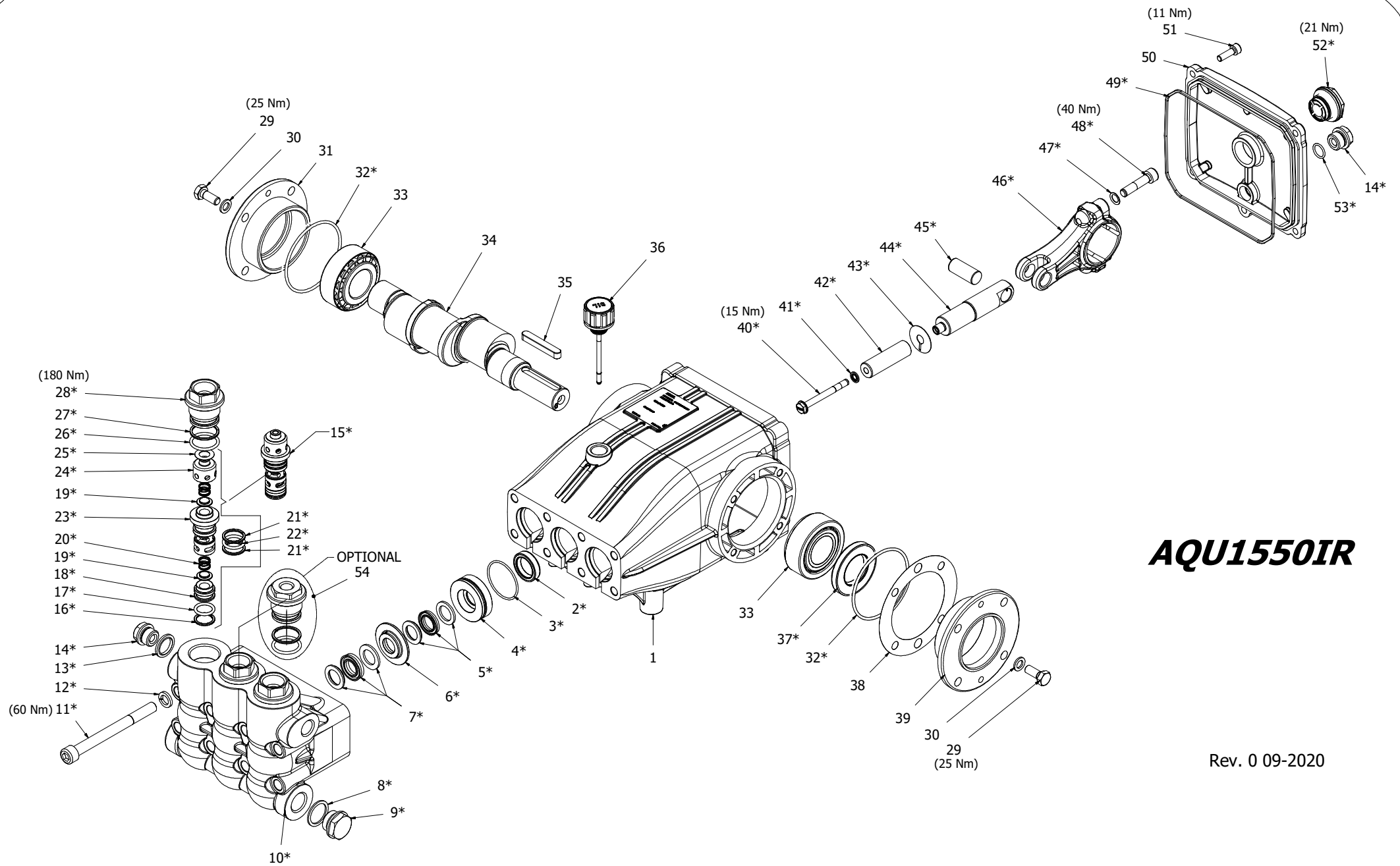

AQU1550IR

Rev. 0 09-2020

**HAWK
Pompe AQUAGROUP PX serie 2020
AQUAGROUP PX pumps 2020 series**

AQUAGROUP PXI SERIES 2020

ORDINARY MAINTENANCE KIT / KIT MANUTENZIONE ORDINARIA

KIT	Item Pos.	Part Number Codice	Description	Descrizione	Q.TY by Pump Q.TA per Pompa	AQU1550IR
A	3- 5- 7	1.099-793.0	PLUNGER SEALS DIA. 16 mm	GUARNIZIONI PISTONE Ø16	1	•
B	15- 25	1.905-688.0	COMPLETE VALVE	VALVOLA COMPLETA	1	

EXTRAORDINARY MAINTENANCE KIT / KIT MANUTENZIONE STRAORDINARIA

KIT	Item Pos.	Part Number Codice	Description	Descrizione	Q.TY by Pump Q.TA per Pompa	AQU1550IR
C	3- 4- 5- 6- 7	1.905-690.0	COMPLETE SEALS PACKING DIA. 16 mm	PACCO COMPLETO GUARNIZIONI PISTONE Ø16	1	•
D	40- 41- 42- 43	1.099-798.0	PLUNGER DIA. 16 mm	PISTONE Ø16	3	
E	2	1.099-766.0	PLUNGER OIL SEALS	ANELLI TENUTA OLIO ASTA	1	
F	14- 32- 37-49 52- 53	1.905-613.0	KIT CRANKCASE SEALS	KIT TENUTE CARTER	1	
G	3- 4- 5- 6- 7- 8 9- 10- 11- 12 13- 14- 15- 25 26- 27- 28	1.099-800.0	COMPLETE MANIFOLD	TESTATA COMPLETA	1	
H	40- 41- 44- 45 46- 47- 48	1.905-695.0	CONNECTING ROD PLUNGER ROD ASSY	PREMONTATO ASTA-BIELLA PISTONE	3	
I	26- 27- 28	1.904-324.0	VALVE PLUG ASSY	PREMONTATO TAPPO VAM	6	

“Q.TY by Pump” => Necessary quantity to repair one pump
 “Q.TA’ per Pompa” => Quantità necessaria per riparare una pompa

OPTIONAL

Item Pos.	Part Number Codice	Description	Descrizione	Q.TY by Pump Q.TÀ per Pompa	AQU1550IR
54	1.904-422.0	THREADED BRASS PLUG G1/4	PREMONTATO TAPPO FORATO	1	•

TOOL KIT

Part Number Codice	Description	Descrizione	Q.TY by Pump Q.TÀ per Pompa	AQU1550IR
1.099-665.0	TOOL-KIT	TOOL-KIT	1	•
1.905-659.0	OIL SEAL EXTRACTOR TOOL-KIT	TOOL-KIT ESTR. PARAOLIO	1	

IMPORTANT

IMPORTANTE

* **Part available ONLY in kit**
Disponibile SOLO in kit

(...) **Parts pre-assembled**
Parti pre-assemblate

PARTS LIST LISTA PARTI

Item Pos	Part Number Codice	Description	Descrizione	KIT	Q.TY Q.TA	AGU1550IR
1	9.850-377.0	CRANKCASE	CARTER		1	
2*		PLUNGER OIL SEAL	ANELLO RADIALE Ø20X30X7	E	3	
3*		"O" RING 2150 - Ø1.78X37.82	"O" RING 2150 - Ø1.78X37.82	A-C-G	3	
4*		PRESSURE RING 16 MM	PRESSORE Ø16	C-G	3	
5*		"U" SEAL, DIA.16 MM	ANELLO TENUTA "U" Ø16	A-C-G	3	
6*		INTERMED. RING 16 MM	DIFFUSORE INTERM. Ø16	C-G	3	
7*		"U" SEAL, DIA.16 MM	ANELLO TENUTA "U" Ø16	A-C-G	3	
8*		COPPER WASHER 1/2	GUARNIZIONE RAME G1/2	G	1	
9*		BRASS PLUG G1/2	TAPPO G1/2	G	1	
10*		MANIFOLD HOUSING	TESTATA	G	1	
11*		MANIFOLD STUD BOLT	VITE M10X110	G	8	
12*		LOCK-WASHER	ROSETTA ELASTICA Ø10,2	G	8	
13*		BONDED SEAL G 3/8	BONDED SEAL G 3/8	G	1	
14*		BRASS PLUG 3/8	TAPPO G3/8	F-G	2	
15*		VALVE ASSEMBLY	VALVOLA PREMONTATA	B-G	3	
16*		BACK RING	ANELLO ANTIESTR. OR119	G	3	
17*		"O" RING 119 - Ø2,62X15,08 90SH	"O" RING 119 - Ø2,62X15,08 90SH	G	3	
18*		VALVE SEAT	SEDE VALVOLA	G	3	
19*		VALVE PLATE	PIATTELLO VALVOLA	G	6	
20*		VALVE SPRING	MOLLA VALVOLA	G	6	
21*		BACK RING	ANELLO ANTIESTR. OR3068	G	6	
22*		"O" RING 3068 - Ø2.62X17.13	"O" RING 3068 - Ø2.62X17.13	G	3	
23*		VALVE CAGE	GABBIA VALVOLA	G	3	
24*		VALVE CAGE	GABBIA VALVOLA	G	3	
25*		COPPER WASHER	ROSETTA VALVOLA	B-G	3	
26*		"O" RING 3093 - Ø2,62X23,47	"O" RING 3093 - Ø2,62X23,47	G-I	3	
27*		BACK RING	ANELLO ANTIESTR. OR3093	G-I	3	
28*		VALVE PLUG	TAPPO VALVOLA	G-I	3	
29	9.851-503.0	HEXAGONAL SCREW	VITE M8X20		8	
30	9.851-114.0	WASHER	ROSETTA Ø8.5		8	
31	9.850-624.0	CLOSED BEARING HOUSING	FLANGIA CHIUSA		1	
32*		"O" RING Ø2.62X71.12	"O" RING Ø2.62X71.12	F	2	
33	9.850-348.0	ROLLER BEARING	CUSCINETTO A RULLI		2	
34	9.850-193.0	CRANKSHAFT Ø24	ALBERO ECCENTRICO Ø24		1	
35	9.850-447.0	CRANKSHAFT KEY	CHIAVETTA		1	
36	9.851-287.0	OIL DIP STICK	TAPPO LIVELLO OLIO		1	
37*		CRANKSHAFT SEAL	ANELLO RADIALE	F	1	
38	9.850-546.0	SHIM	DISTANZIALE		1	

Item Pos	Part Number Codice	Description	Descrizione	KIT	Q.TY Q.TÀ	AGU1550IR
39	9.850-597.0	BEARING HOUSING	FLANGIA APERTA		1	
40*		PLUNGER BOLT	VITE PISTONE	D-H	3	
41*		BONDED SEAL	BONDED SEAL	D-H	3	
42*		PLUNGER 16 MM	PISTONE Ø16	D	3	
43*		COPPER SPACER	ROSETTA RAME	D	3	
44*		PLUNGER ROD	ASTA PISTONE	H	3	
45*		CONNECTING ROD PIN	SPINOTTO	H	3	
46*		CONNECTING ROD	BIELLA COMPLETA	H	3	•
47*		SPRING WASHER	ROSETTA ELASTICA Ø8	H	6	
48*		CONNECTING ROD SCREW	VITE M8X35	H	6	
49*		"O" RING Ø2,62X152,07	"O" RING Ø2,62X152,07	F	1	
50	9.850-389.0	CRANKCASE COVER	COPERCHIO		1	
51	9.851-474.0	COVER SCREW	VITE M6X20		5	
52*		SIGHT GLASS, G3/4	SPIA LIVELLO OLIO G3/4	F	1	
53*		"O" RING Ø1,78X14,00	"O" RING Ø1,78X14,00	F	1	