

# PANDA 215 SMALL HP

TAV.312/1/HP  
22/05/2006

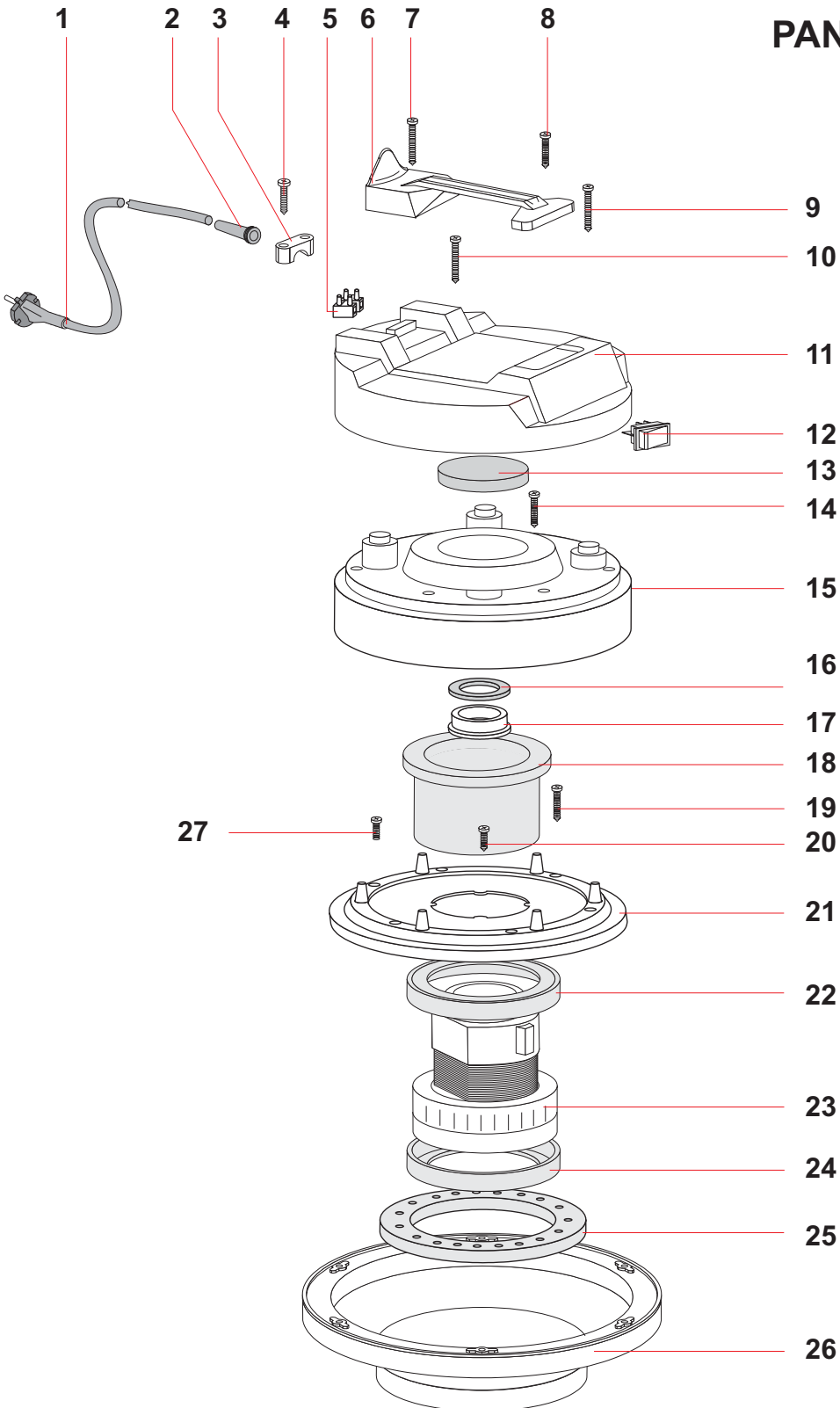

TESTATA PANDA 215-515 HP			REF.3780 P HP
POS.	REF.	DESCRIZIONE	N°
1	117	CAVO ELETTRICO 2X1	1
2	138	PASSACAVO	1
3	139	BLOCCACAVO	1
4	1006	VITE PFU TMT PHL 5X20 ZN.NERA P/R	2
5	3464	MORSETT. 300/500 EU/NEV/RAD	1
6	3733	MANIGLIA PANDA	1
7	2627	VITE PAT TMT PHL 5X40 ZN.NERA	4
8	1006	VITE PFU TMT PHL 5X20 ZN.NERA P/R	2
9	1026	VITE PAT TMT PHL 5X30 ZN.NERA	2
10	1026	VITE PAT TMT PHL 5X30 ZN.NERA	2
11	3734	COPERCHIO PANDA	1
12	326	INTERUTTORE	1
13	3937	FILTRO MTP/65 Ø 95	1
14	1050	VITE PAT TMT PHL 5X35 ZN.NERA	6
15	2738	COPERTURA 99 S/FORI	1
16	3969	RONDELLA H=8 Ø 85 X 65	1
17	310	ANELLO MOTORE PLAST. H=15	1
18	3900	FILTRO MTP/65 Ø 160-120 H=88	1
19	2627	VITE PAT TMT PHL 5X40 ZINC.	6
20	1006	VITE PFU TMT PHL 5X20 ZN.NERA P/R	4
21	2591	FERMAMOTORE 99	1
22	3901	GUARNIZIONE AL S/F H=5,5	1
23	20047	MOT.BS282 1200W 230V 50/60 MONO	1
24	7711	GUARNIZIONE AL S/F H=16	1
25	3866	RONDELLA MTP/65 MM.18 Ø 230X145	1
26	1189 GP	BASAMENTO 500 C/GUARN.E PIASTRINA	1
27	3189	VITE TC CROCE M 5X30 UNI 7989	1
*	1107	CAVETTO C/RESISTENZE	1
*	7632	KIT ELETTR. 40CM MOTORE	1
*	1106	FASCETTA	1
*	1103	FASTON	2

KIT FILTRANTE YES COMPL. REF.6052			
POS.	REF.	DESCRIZIONE	N°
1	3706	BUSSOLA Ø 8 PLAST	4
2	3724	VITE PAT TMT PHL 5X25 INOX	4
3	2823	CORPO ANTISCHIUMA 99 ALTO	1
4	2676	GALLEGGIANTE 99 ALTO	1
5	507	ANELLO PORTAFILTRO SERIE 500	1
6	2862	FILTRO POLYESTERE 300 CONICO BASSO	1
7	2861	CESTELLO 300 CONICO BASSO	1

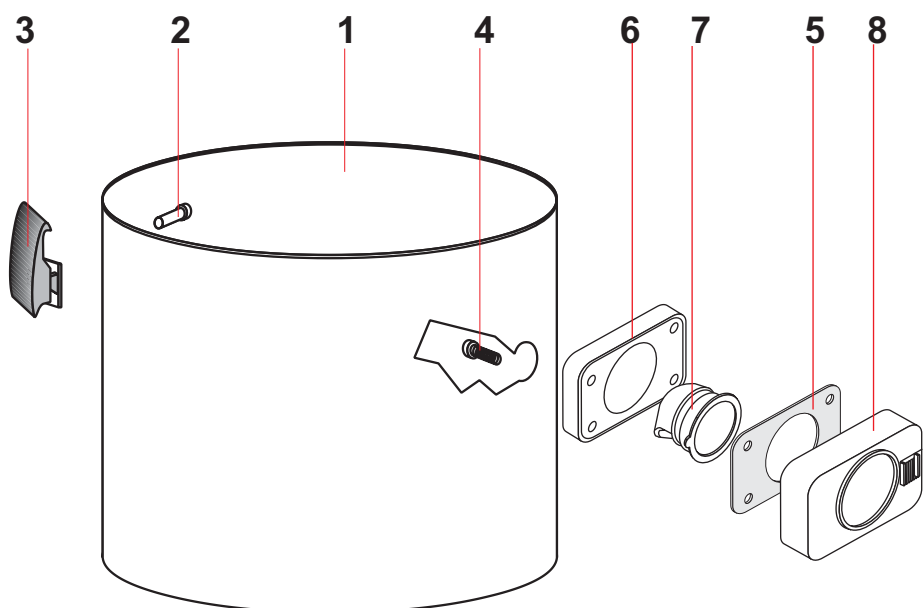
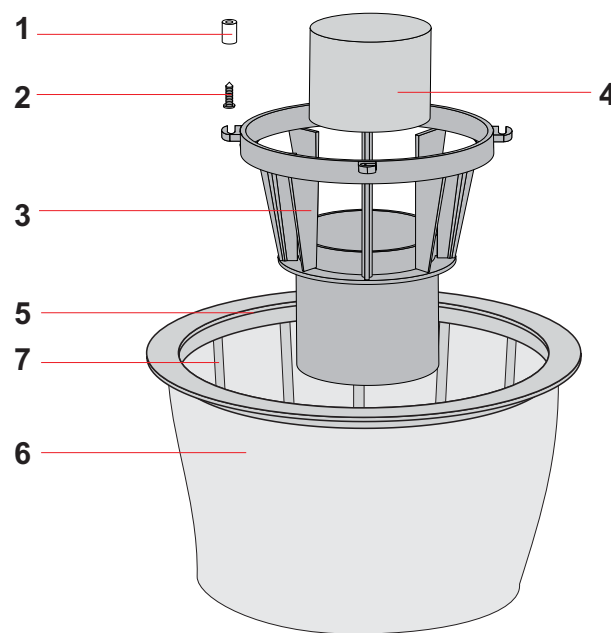

FUSTO 215 AISI 430 H=240 COMPLETO REF.3300			
POS	REF	DESCRIZIONE	N°
1	3299	FUSTO 215 AISI 430 H=240	1
2	1301	RIVETTO 5X11	4
3	1847/S	GANCIO PLASTICA COMPLETO	2
4	1026	VITE TRUCC.T 1/2 TONDA CROCE 5X30	4
5	2846	GUARNIZIONE Ø 38	1
6	2586	GUARNIZIONE R 205	1
7	2593	DEFLETTORE 99	1
8	2652 A	BOCCHETTONE R155	1

CARRELLO 202 QUADRO REF.1219			
POS.	REF.	DESCRIZIONE	N°
1	1218	CORPO CARRELLO QUADRO	1
2	558	RUOTA CARRELLO BOX	4

